

The Voltage Regulator and Modeling the Diode Resistance

Circuit 1A shows a 2.1V regulator using 3 diodes in series. The circuit is modeled using the 0.7 CVD model. Circuits 1B and 1C show the circuits used for finding the transfer function for both FB and RB.

$$v_R(v_S) = 2.1 \text{ V}, \quad \text{for } v_S > 2.1 \text{ V}$$

$$v_R(v_S) = v_S, \quad \text{for } v_S < 2.1 \text{ V}$$

Based on this analysis, the regulator behaves ideally as long as the source voltage, v_S , is greater than 2.1 V. For $v_S > 2.1 \text{ V}$, the regulated voltage, v_R , stays steady at 2.1 V regardless of any noise or spikes on the source voltage.

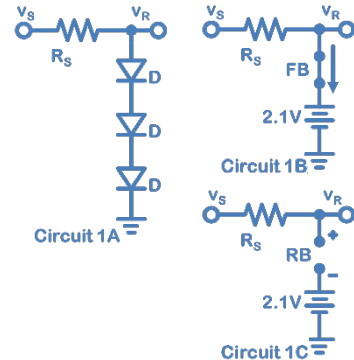

However, measurements of an actual regulator constructed with real diodes do not show this ideal behavior, and there is some variation in the regulated voltage due to a change in the source voltage. This relationship ($\Delta v_R / \Delta v_S$) is referred to as **line regulation** and has an ideal value of 0 (what the analysis using CVD model shows, but not with the actual device).

The Question: Why does the actual circuit show a change in the regulated voltage with a change in the source voltage when CVD analysis does not show this behavior?

The Answer: Because the CVD model is a simplified and does not account for the slope of the exponential i-v characteristic in forward bias.

The Problem: The CVD model is not good enough to account for how the diode reacts to small variations in the circuit, but the exponential model is too complicated to use for circuit analysis.

The key feature missing in the CVD model is the slope of the exponential characteristic near the operating point of the diode (V_D, I_D). A slope in the i-v relationship is modeled using a resistor, r_d .

The Solution: A small resistor, r_d , is added in series with the CVD model (total of $3r_d$ since there are 3 diodes). A more accurate transfer function $v_R(v_S)$ is obtained.

$$v_R(v_S) = 2.1 + \frac{3r_d}{R_S + 3r_d} (v_S - 2.1) \quad \text{for } v_S > 2.1, \quad \text{and } v_R(v_S) = v_S \quad \text{for } v_S < 2.1$$

Here we see that $\Delta v_R / \Delta v_S = 3r_d / (R_S + 3r_d)$. The value of r_d is determined by evaluating the slope of our exponential model at the CVD operating point (V_D, I_D). For this case,

CVD analysis: $I_D = \frac{(v_S - 2.1)}{R_S} e^{\frac{v_D}{nV_T}}$ *no resistor r_d included*

Slope (di_D/dv_D): $\frac{di_D}{dv_D} = \frac{I_S e^{\frac{v_D}{nV_T}}}{nV_T}$

Evaluated at I_D : $\left. \frac{di_D}{dv_D} \right|_{(V_D, I_D)} = \frac{I_S e^{\frac{V_D}{nV_T}}}{nV_T} = \frac{I_D}{nV_T}$

Resistance (1/slope): $r_d = \frac{nV_T}{I_D} = \frac{R_S nV_T}{(v_S - 2.1)}$ *refine the CVD model by adding r_d *

Values of $R_S = 1 \text{ k}\Omega$, $n = 2$, and $v_S = 3.5 \text{ V}$ results in $r_d = 35.7 \Omega$ and a line regulation of $\Delta v_R / \Delta v_S = 0.096$.