

For each circuit B through H, follow the procedure on slide #3 to find the drain current, i_D , and verify the mode which is given for each circuit.

For circuit I, stop at step 3a.

For circuits B through I, draw a complimentary PMOS circuit as shown for circuit A on slide #3.

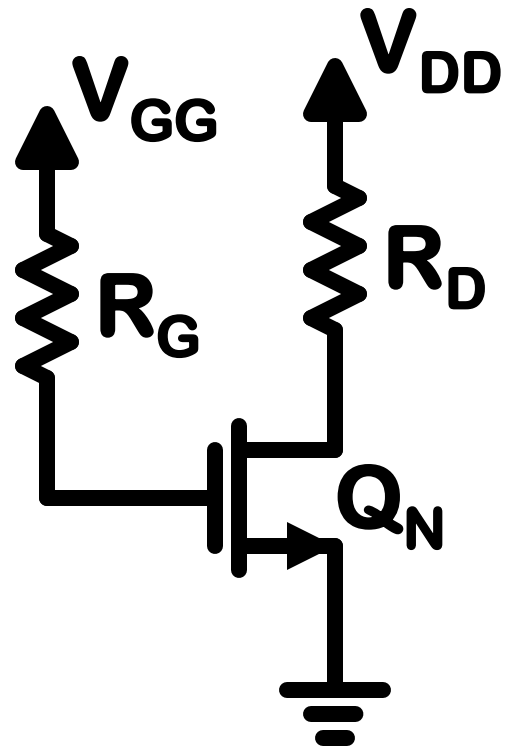

A: Triode

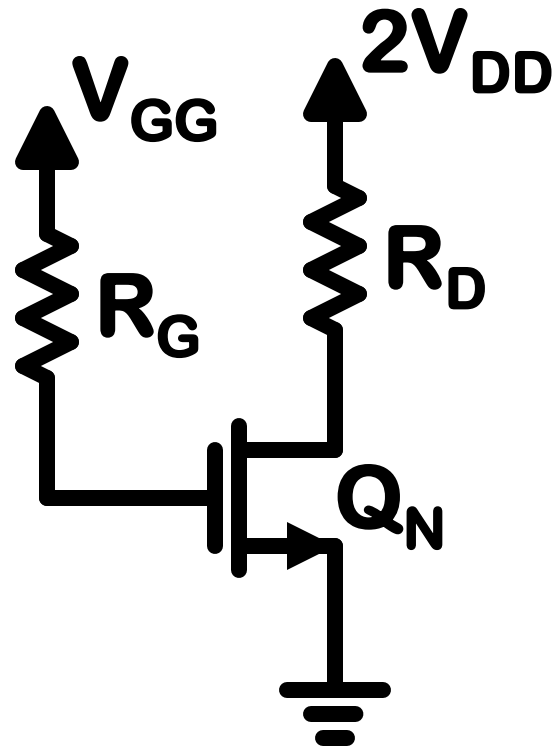

B: Saturation

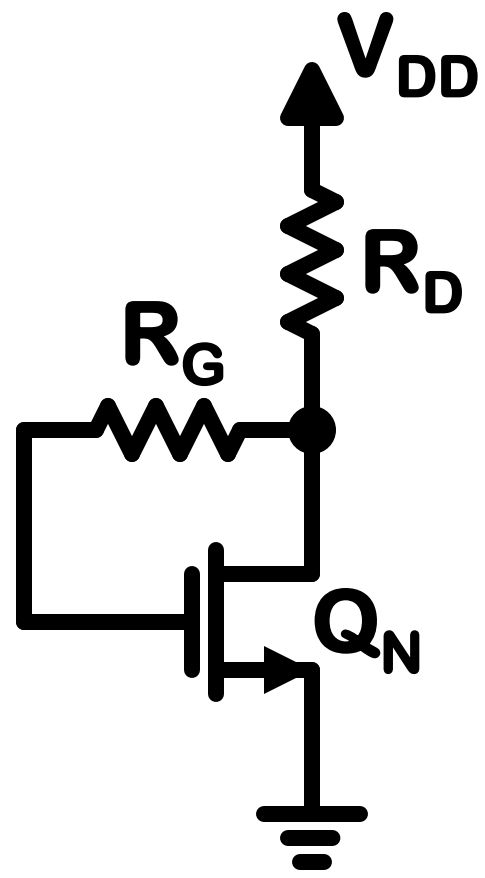

C: Saturation

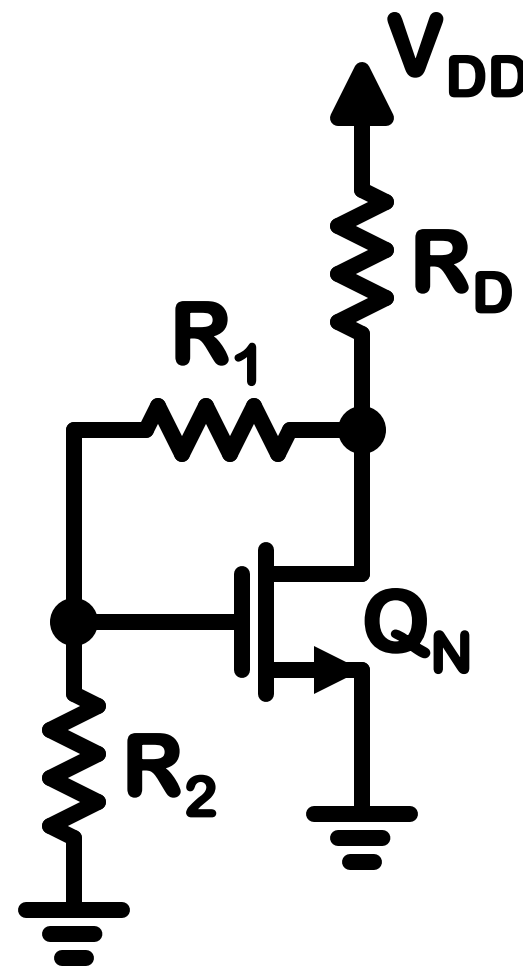

D: Saturation

$V_{DD} = 6V$
 $V_{GG} = 4V$
 $R_G = 10k\Omega$
 $R_D = 500\Omega$
 $R_S = 200\Omega$
 $R_1 = 200\Omega$
 $R_2 = 300\Omega$
 $k_n = 2 \text{ mA/V}^2$
 $V_{tn} = 1V$

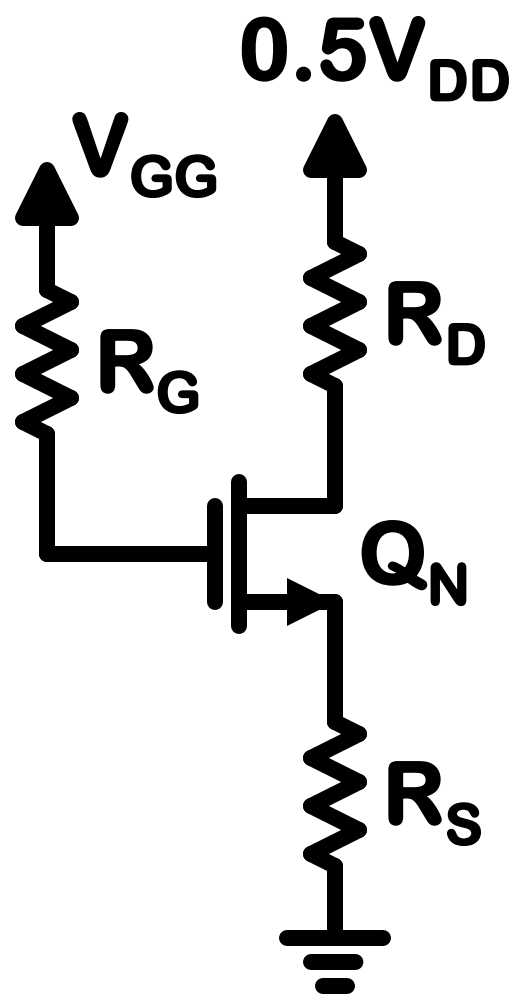

E: Triode

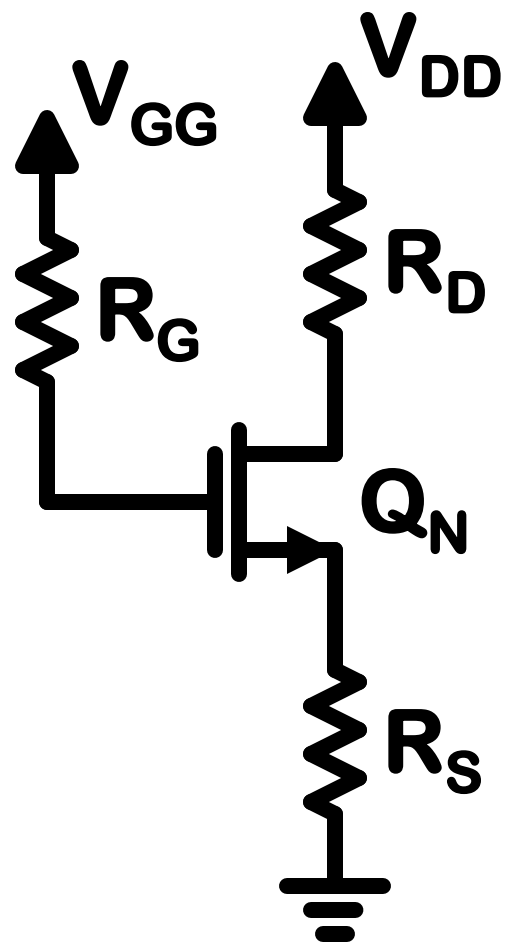

F: Saturation

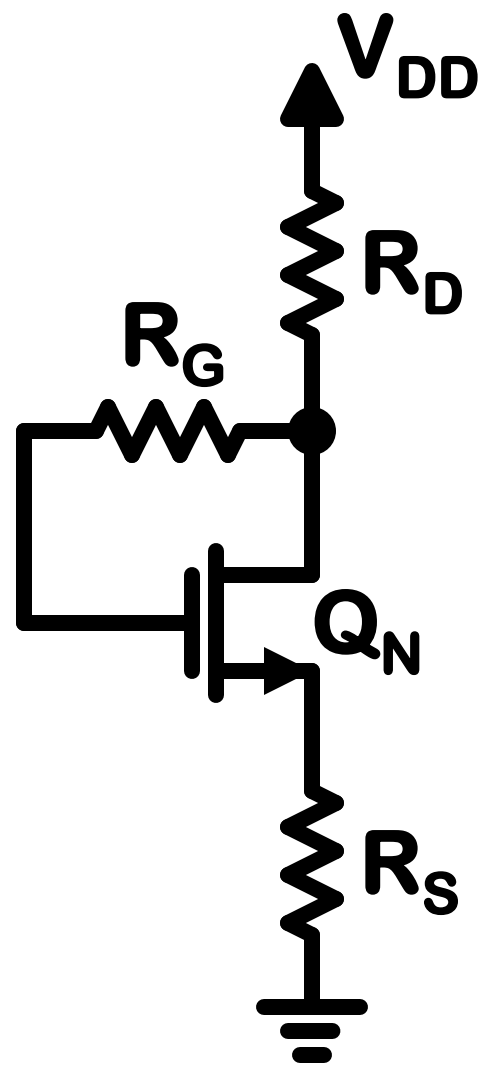

G: Saturation

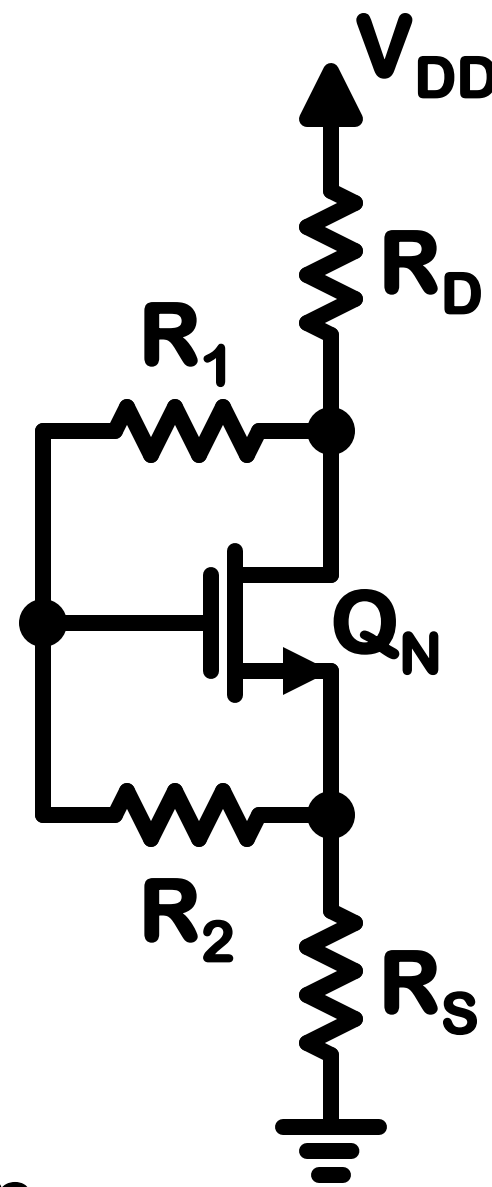

H: Saturation

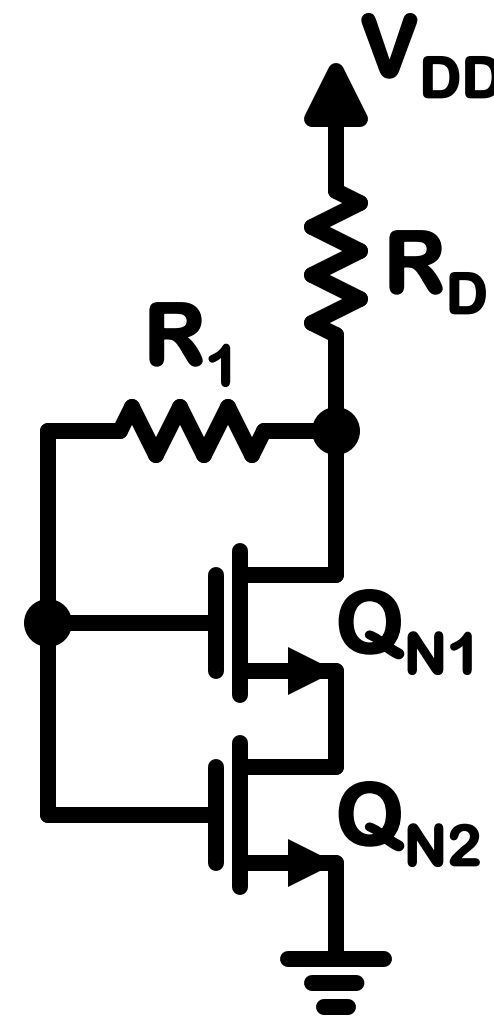

I:
 Q_{N1} : Saturation,
 Q_{N2} : Triode

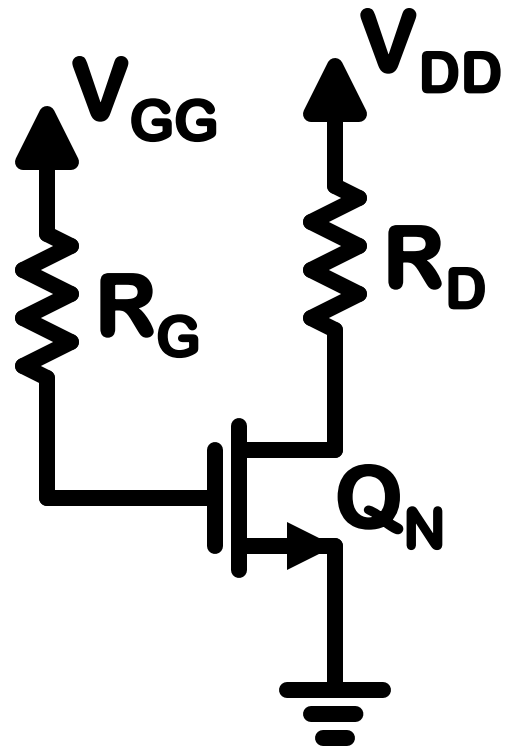

1. Triode

2. Enforce (device equation)

$$i_D = 0.002(v_{GS} - V_{tn} - v_{DS}/2)v_{DS}$$

3. Solve

a. Circuit Equations

$$v_{GS} = 4V$$

$$i_D = (6 - v_{DS})/500$$

b. Solve

$$(6 - v_{DS})/500 = 0.002(4 - 1 - v_{DS}/2)v_{DS}$$

$$6 - v_{DS} = 3v_{DS} - 0.5v_{DS}^2$$

$$0.5v_{DS}^2 - 4v_{DS} + 6 = 0$$

$$v_{DS} = 4 \pm \sqrt{16 - 12} = 6V \text{ or } 2V \dots \text{Choose } 2V$$

$$i_D = (6 - 2)/500 = 4/500 = 8 \text{ mA}$$

4. Check

$$v_{GS} - V_{tn} > 0, \text{ Yes}$$

$$v_{DS} < v_{GS} - V_{tn}, \text{ Yes}$$

