

# CMOS Inverter

$$V_{IN} = 0$$
$$V_{OUT} = V_{DD}$$

$$V_{IN} = V_{DD}$$
$$V_{OUT} = 0$$

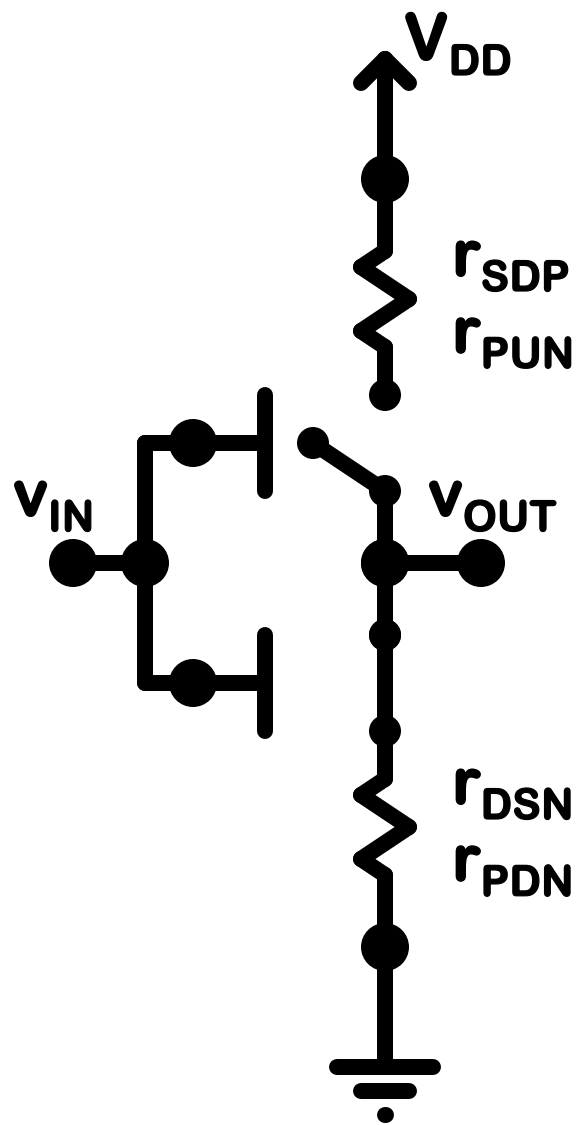
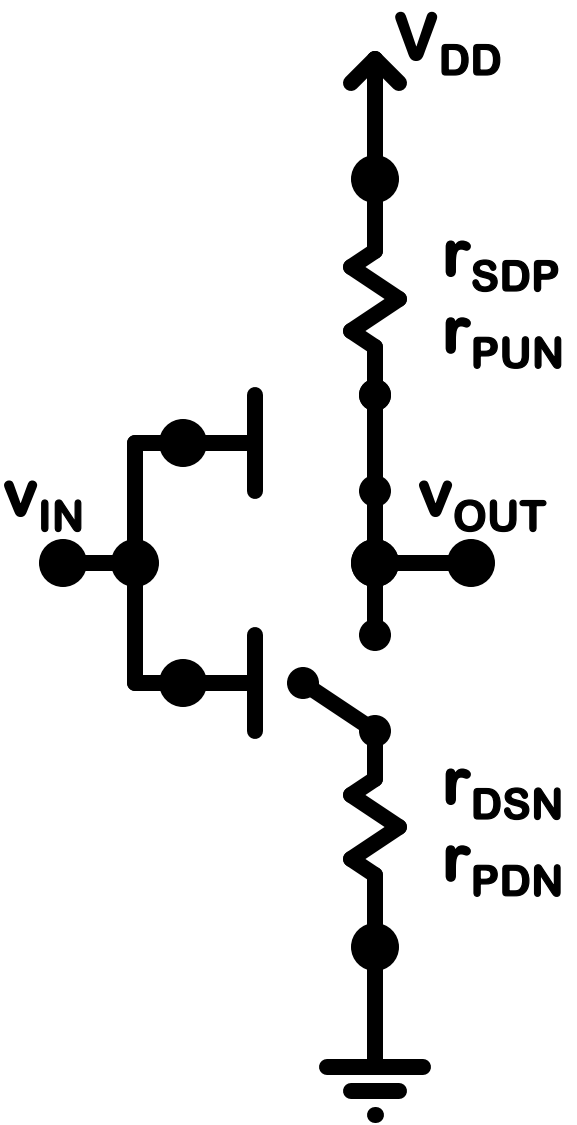
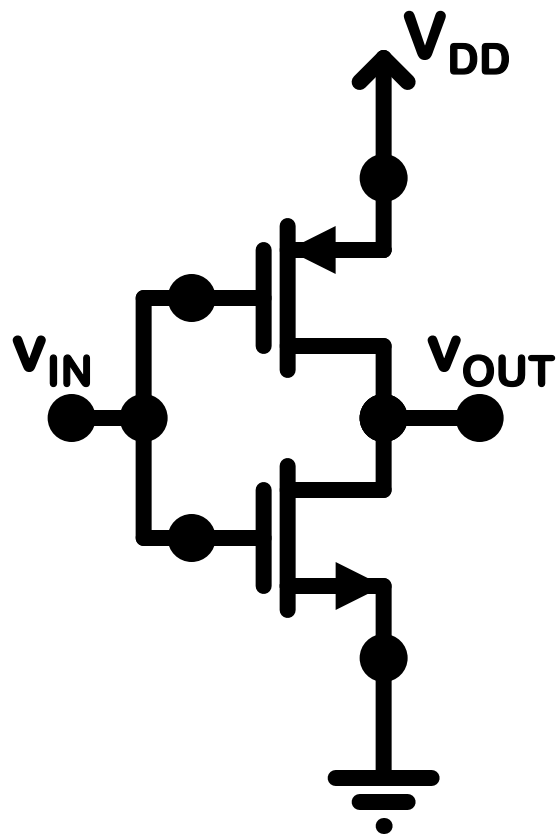

# CMOS Inverter

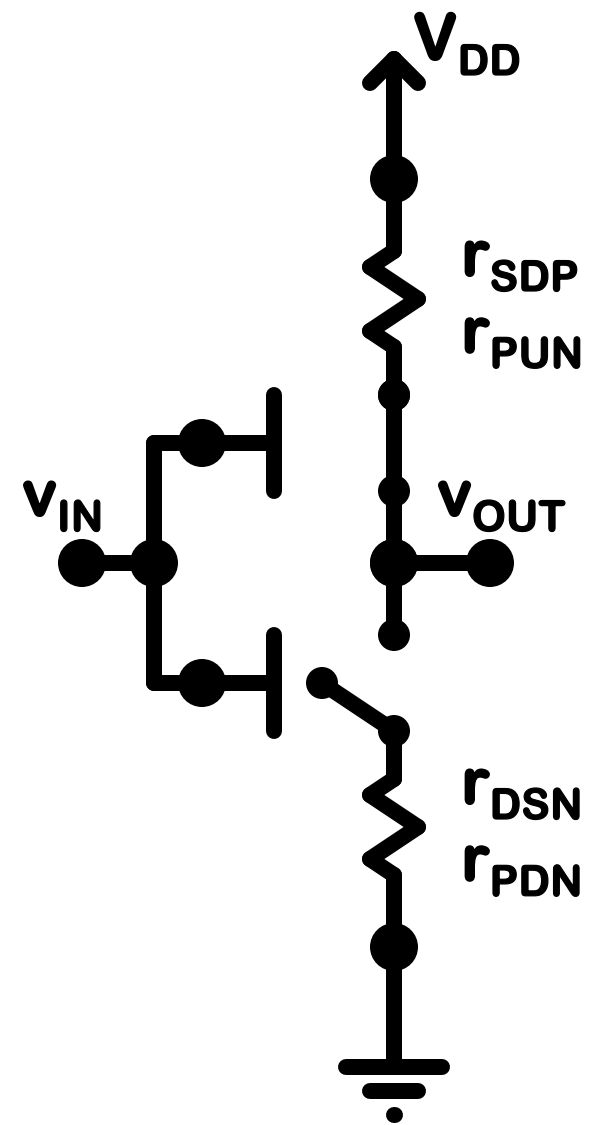
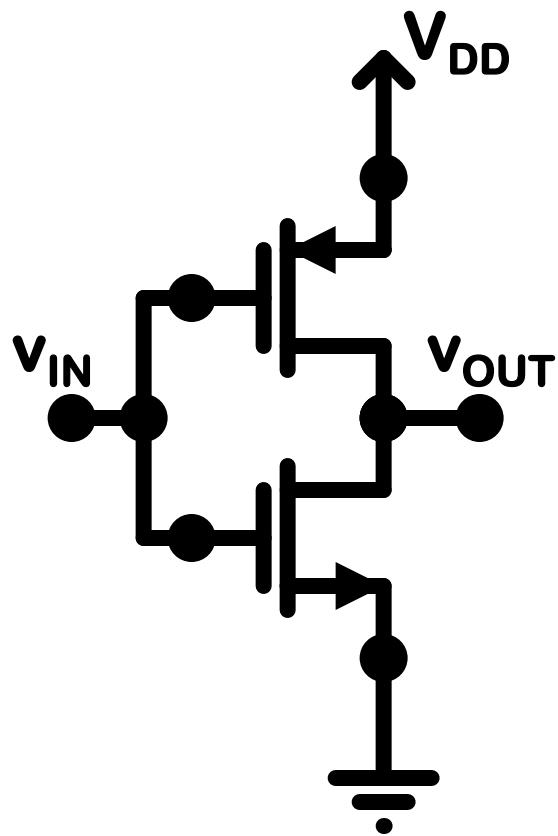

$V_{IN} = 0$   
 $V_{OUT} = V_{DD}$   
 $Q_P$ : Triode small  $v_{SD}$   
 $Q_N$ : Cutoff  
 $r_{PUN} = r_{SDP}$

# CMOS Inverter

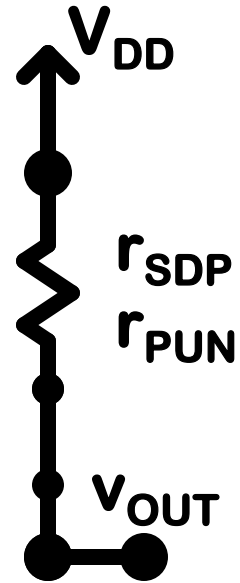
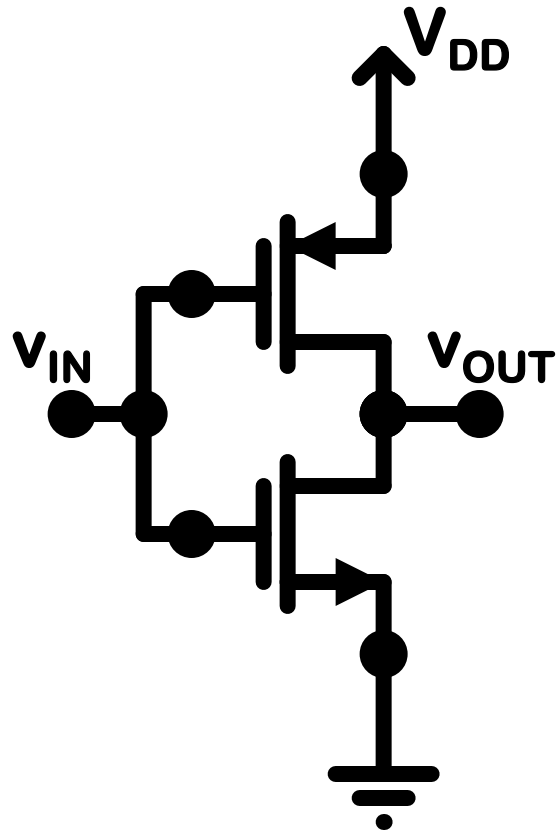

$$V_{IN} = 0$$

$$V_{OUT} = V_{DD}$$

$Q_P$ : Triode small  $v_{SD}$

$Q_N$ : Cutoff

$$r_{PUN} = r_{SDP}$$

# CMOS Inverter

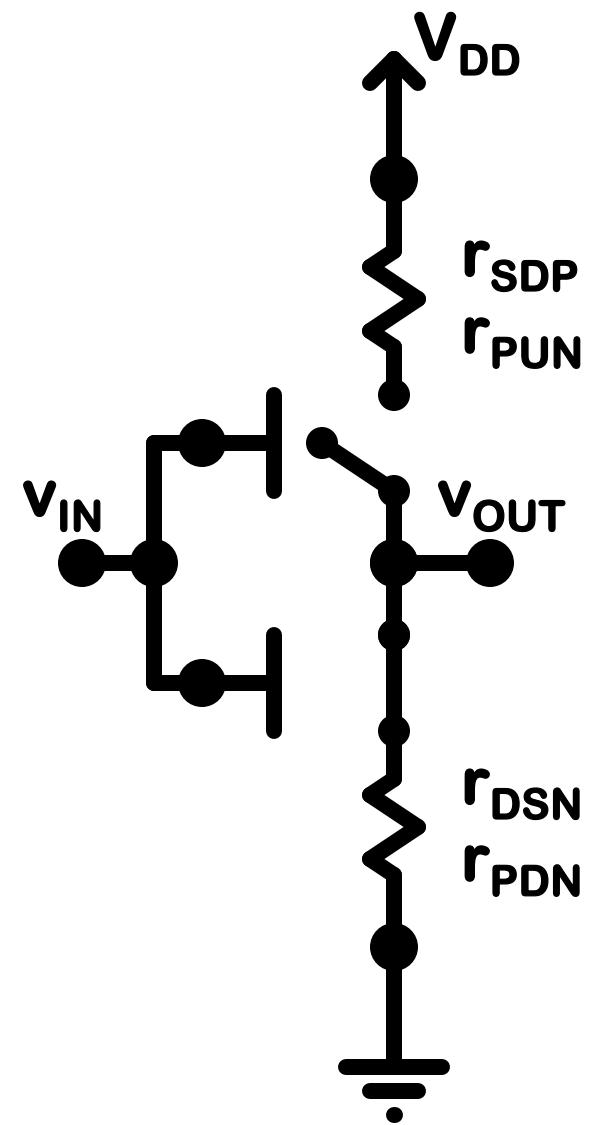
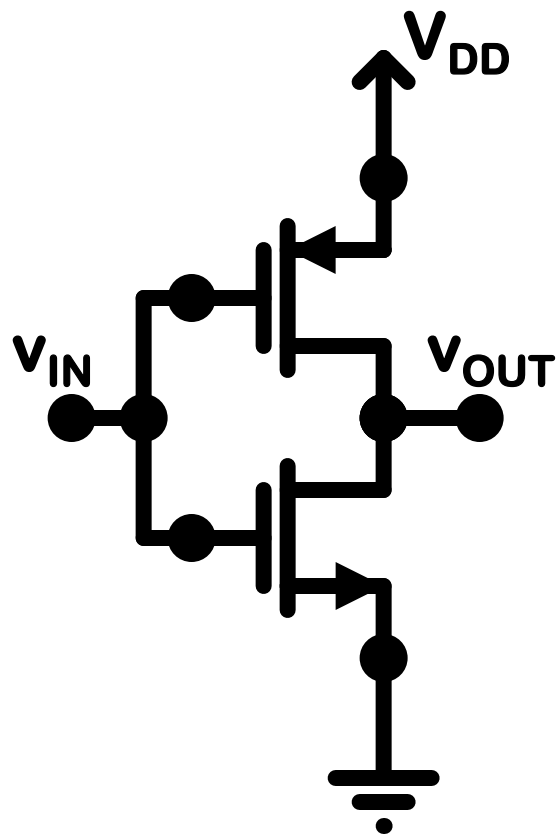

$$V_{IN} = V_{DD}$$

$$V_{OUT} = 0$$

$Q_P$ : Cutoff

$Q_N$ : Triode small  $v_{DS}$

$$r_{PDN} = r_{DSN}$$

# CMOS Inverter

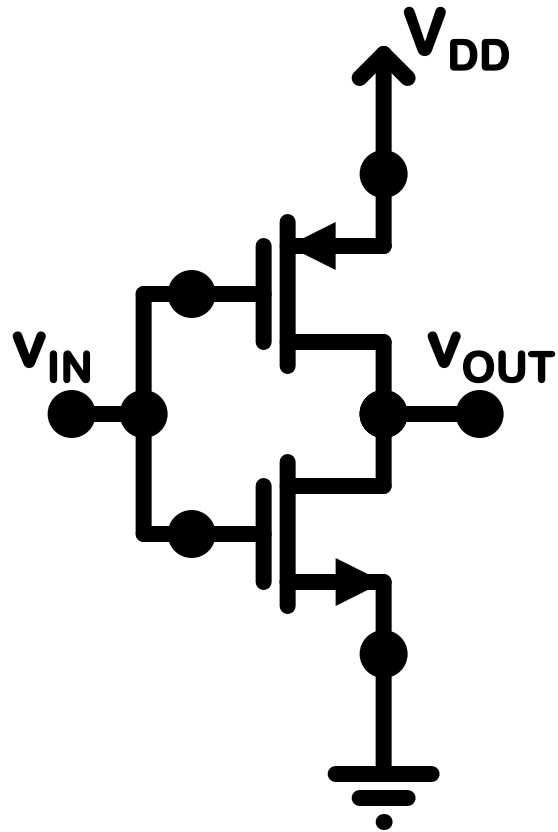

$$V_{IN} = V_{DD}$$

$$V_{OUT} = 0$$

$Q_P$ : Cutoff

$Q_N$ : Triode small  $v_{DS}$

$$r_{PDN} = r_{DSN}$$

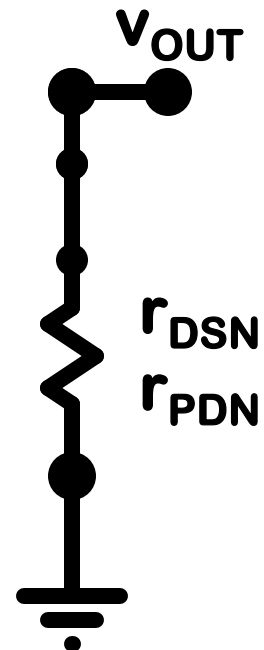

# CMOS Inverter

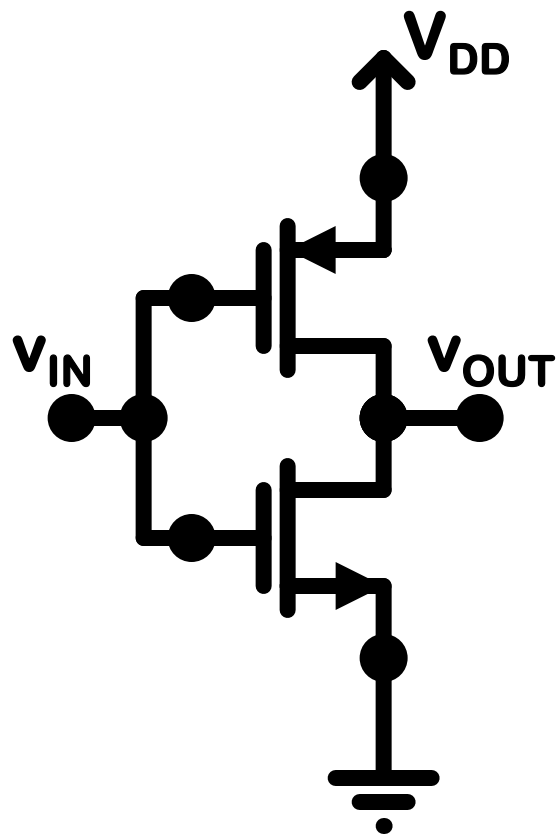

$V_{IN} = V_{DD}$   
 $V_{OUT} = 0$   
 $Q_P$ : Cutoff  
 $Q_N$ : Triode small  $v_{DS}$   
 $r_{PDN} = r_{DSN}$   
 $r_{DSN} = 1/(k_n * (V_{DD} - V_{tn}))$

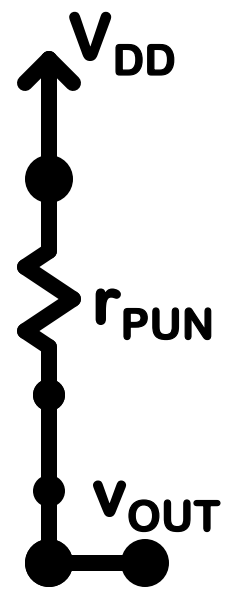

$V_{IN} = 0$   
 $V_{OUT} = V_{DD}$   
 $Q_P$ : Triode small  $v_{SD}$   
 $Q_N$ : Cutoff  
 $r_{PUN} = r_{SDP}$   
 $r_{SDP} = 1/(k_p * (V_{DD} - |V_{tp}|))$

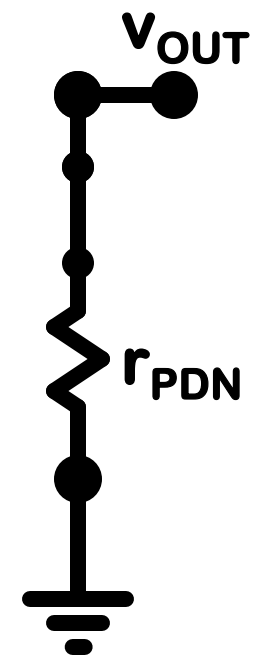

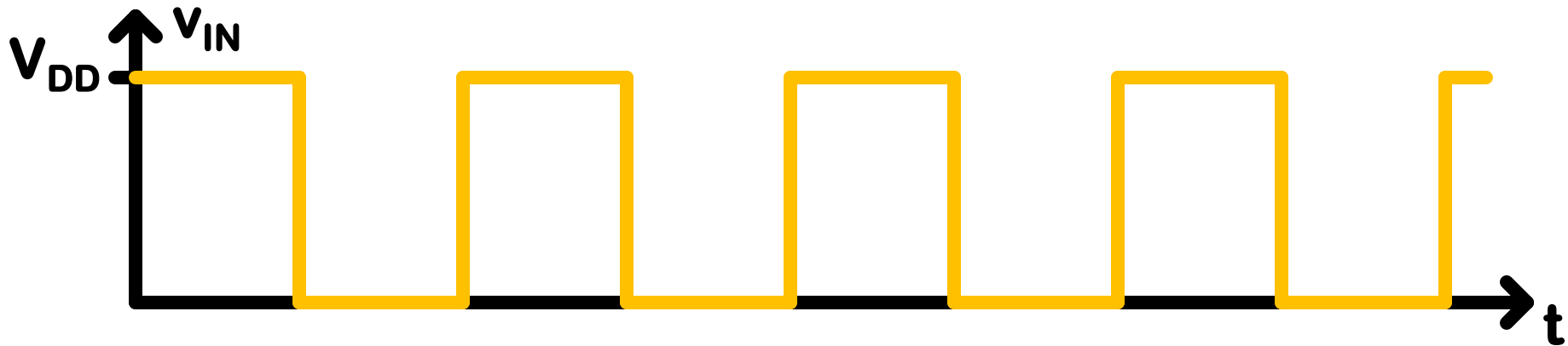

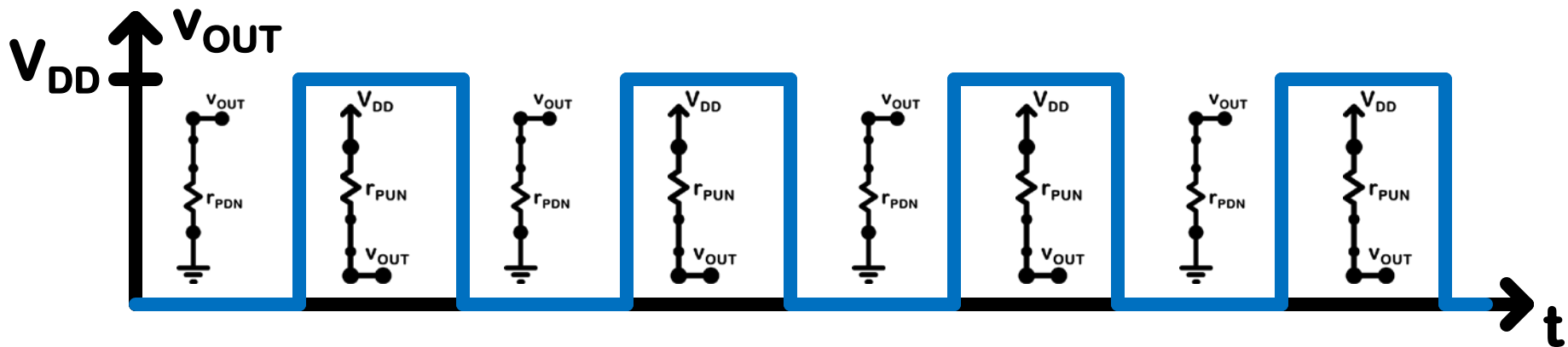
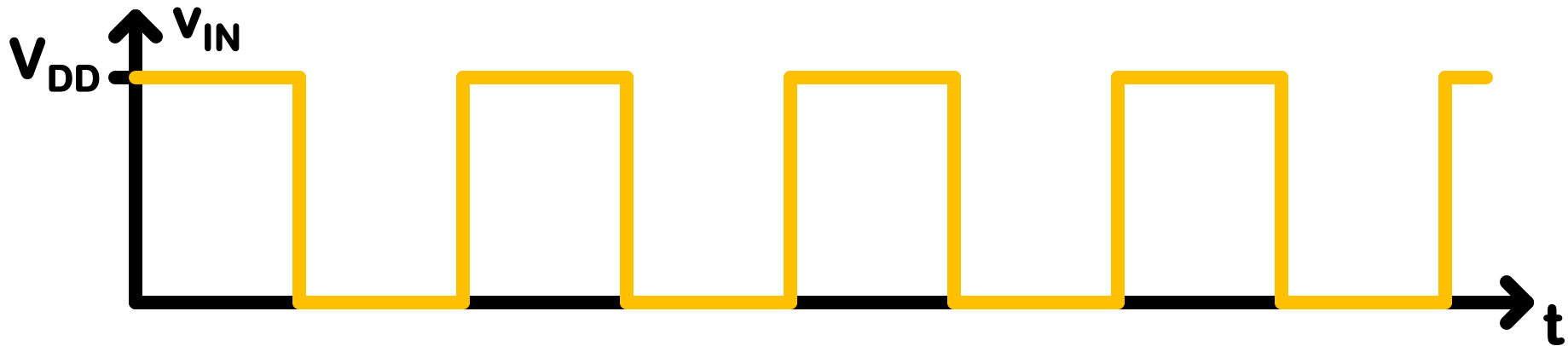

# CMOS Inverter

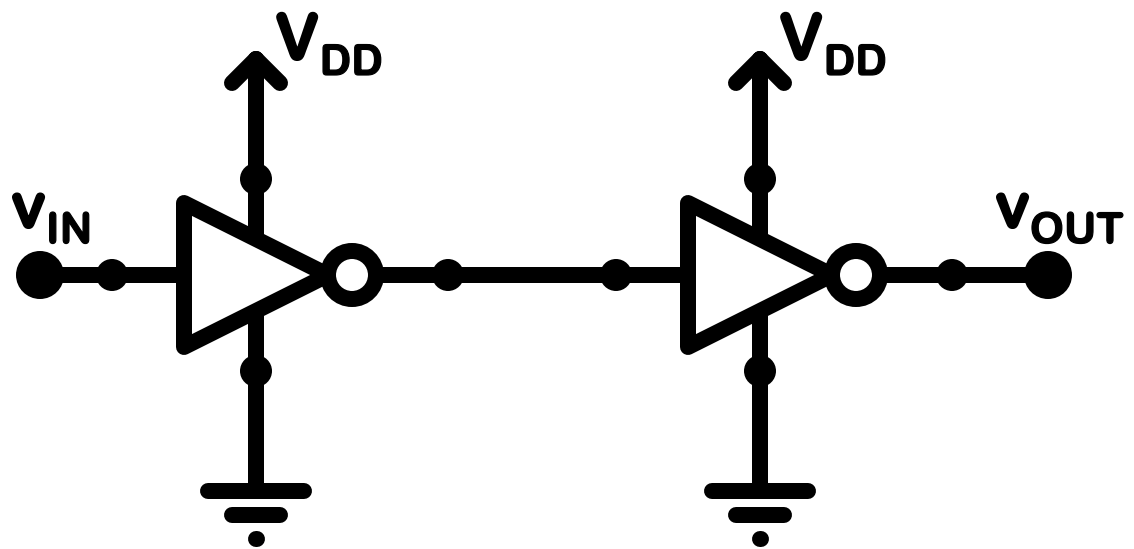

# CMOS Inverter

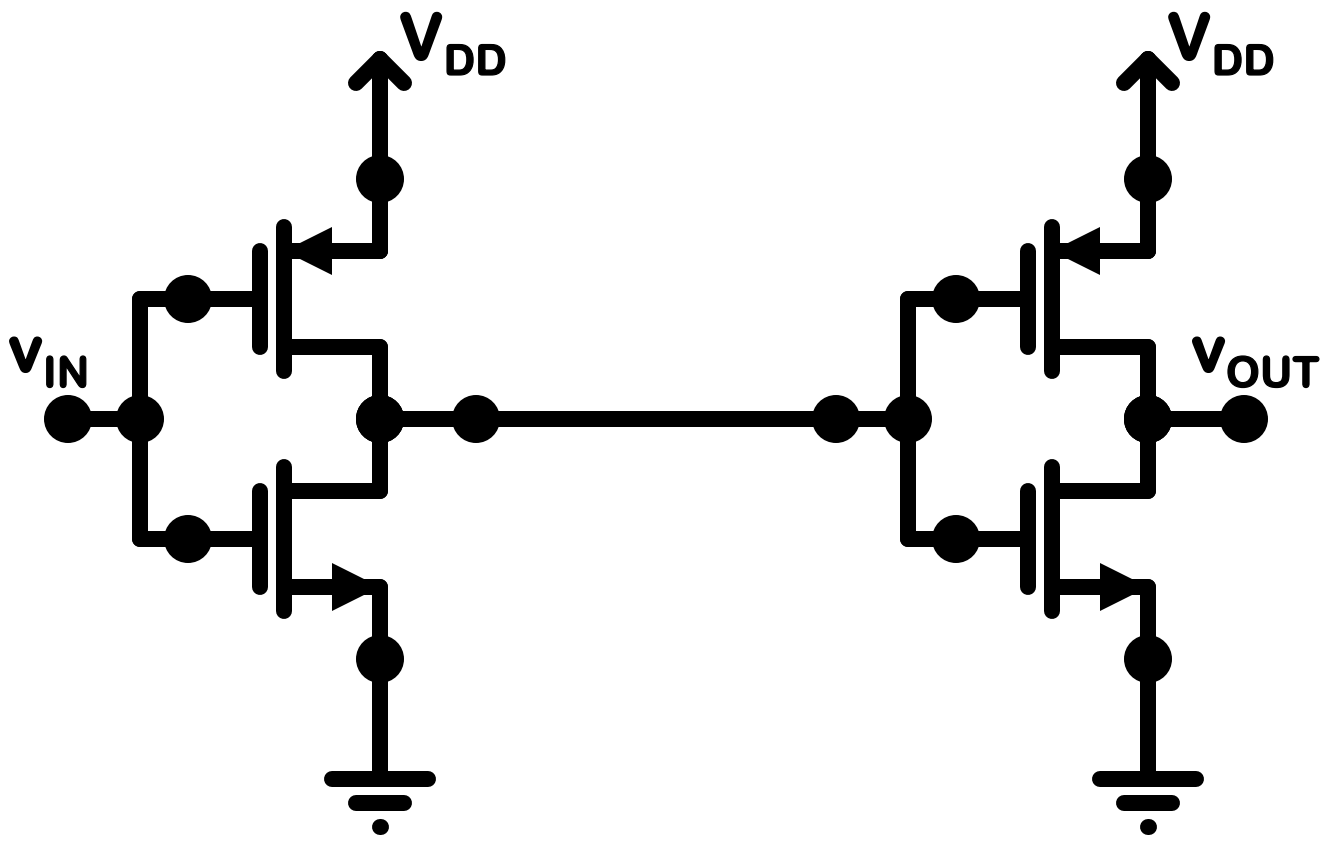

# CMOS Inverter

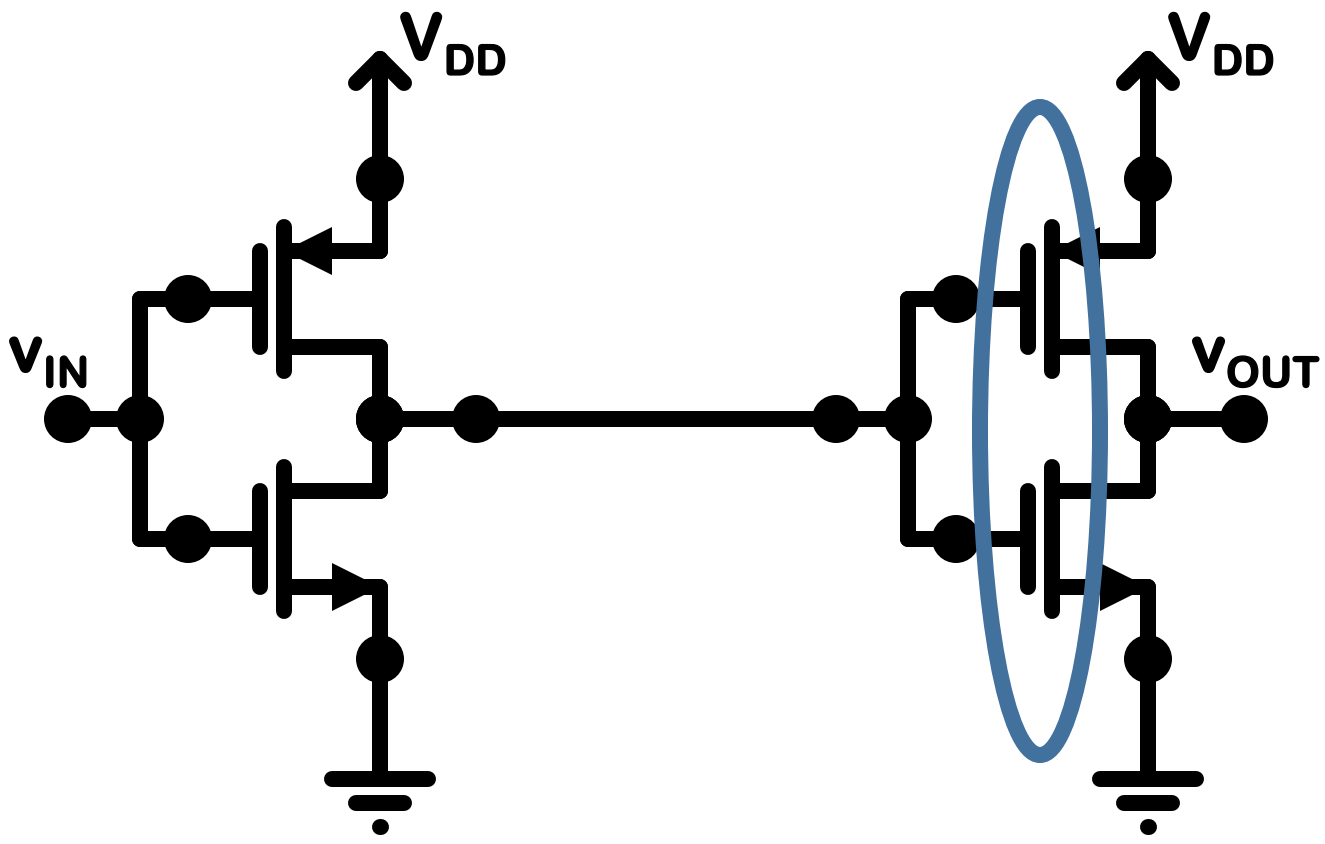

# CMOS Inverter

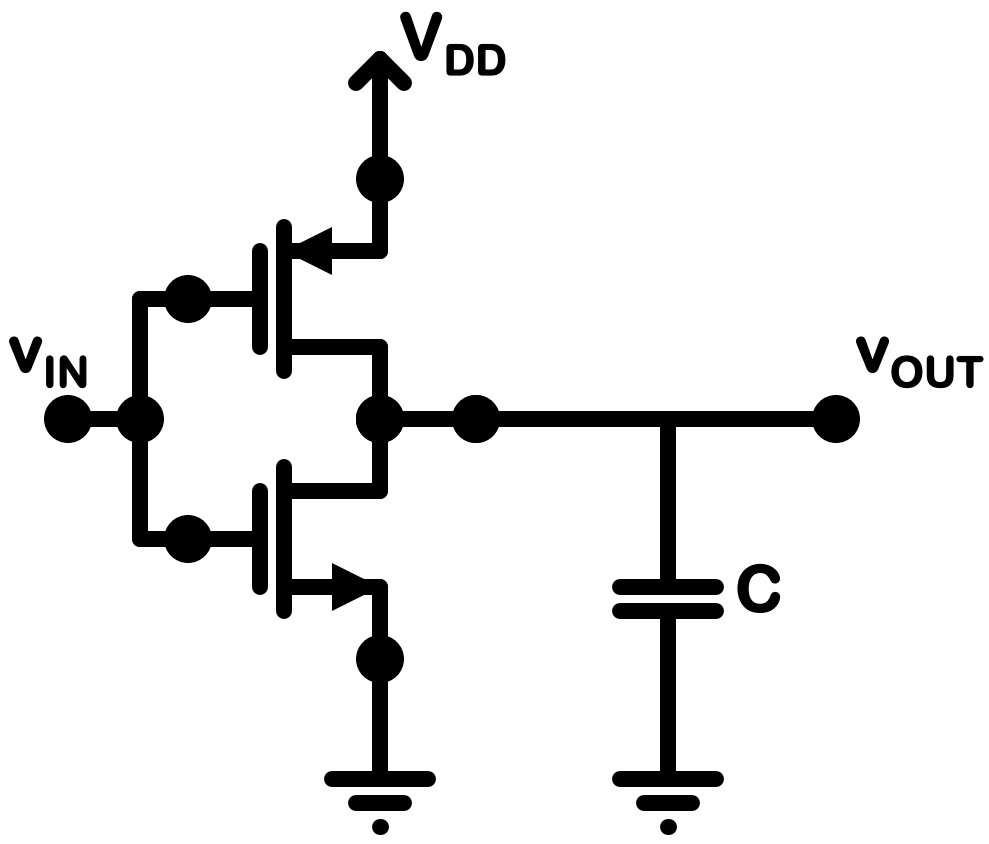

# CMOS Inverter

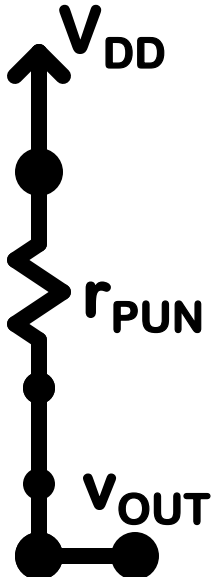
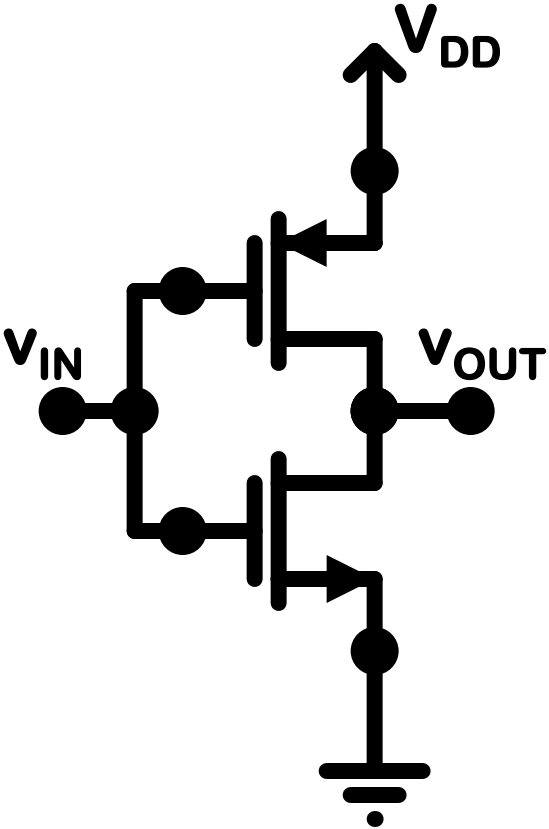

$V_{IN} = V_{DD}$   
 $V_{OUT} = 0$   
 **$Q_p$ : Cutoff**  
 **$Q_n$ : Triode small  $v_{DS}$**   
 $r_{PDN} = r_{DSN}$

$V_{IN} = 0$   
 $V_{OUT} = V_{DD}$   
 **$Q_p$ : Triode small  $v_{SD}$**   
 **$Q_n$ : Cutoff**  
 $r_{PUN} = r_{SDP}$

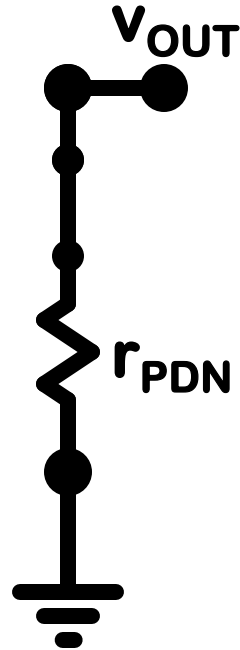

# CMOS Inverter

$V_{IN} = 0$   
 $V_{OUT} = V_{DD}$   
 $Q_P$ : Triode small  $v_{SD}$   
 $Q_N$ : Cutoff  
 $r_{PUN} = r_{SDP}$

$V_{IN} = V_{DD}$   
 $V_{OUT} = 0$   
 $Q_P$ : Cutoff  
 $Q_N$ : Triode small  $v_{DS}$   
 $r_{PDN} = r_{DSN}$

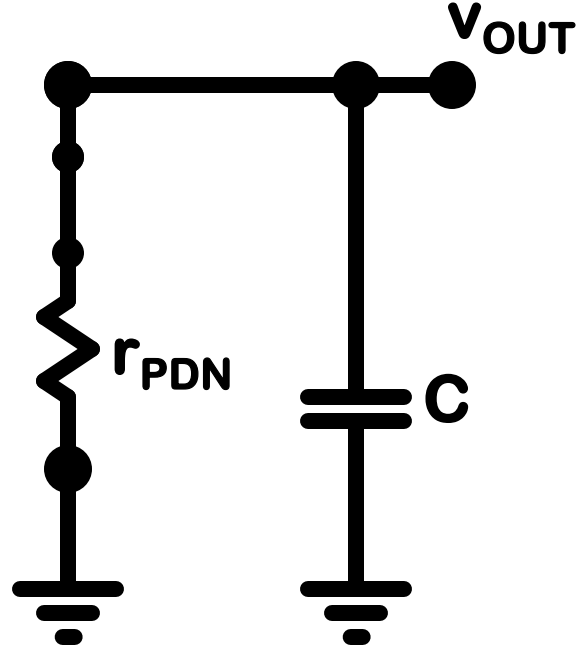
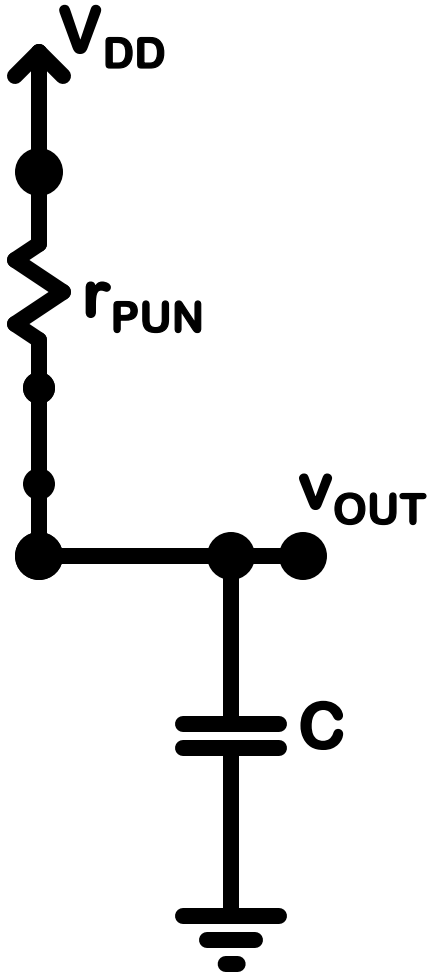
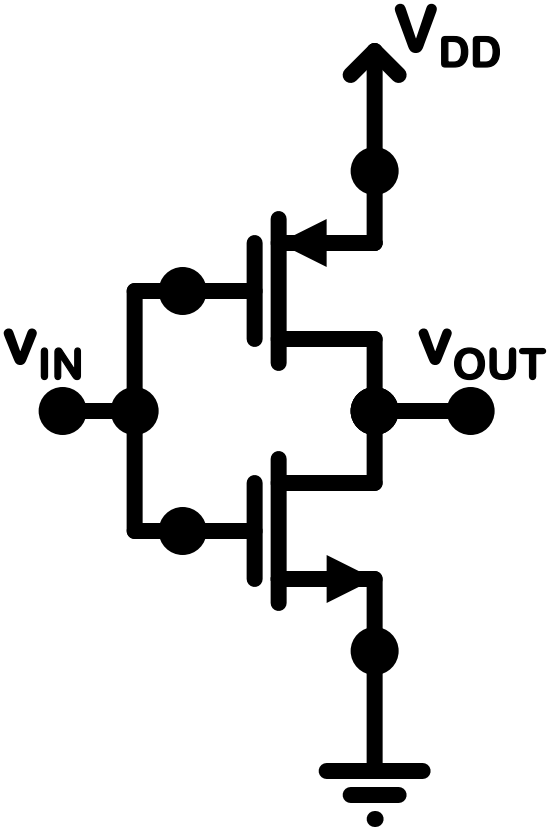

# CMOS Inverter

$$V_{IN} = 0$$
$$V_{OUT} = V_{DD}$$

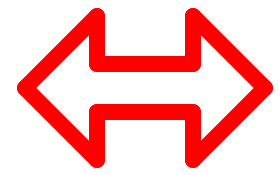
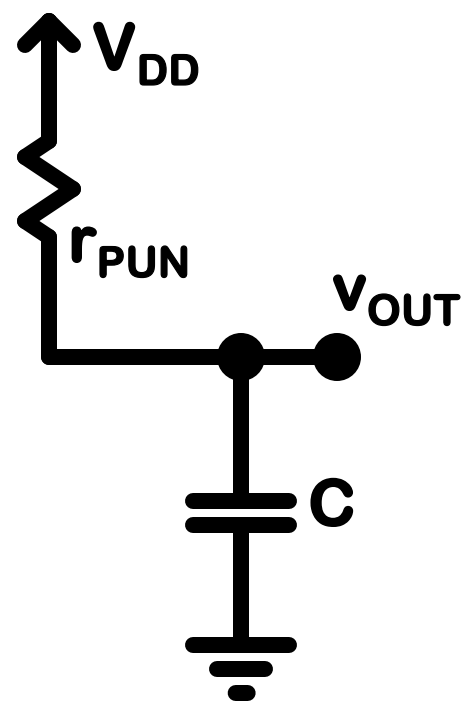

$$V_{IN} = V_{DD}$$
$$V_{OUT} = 0$$

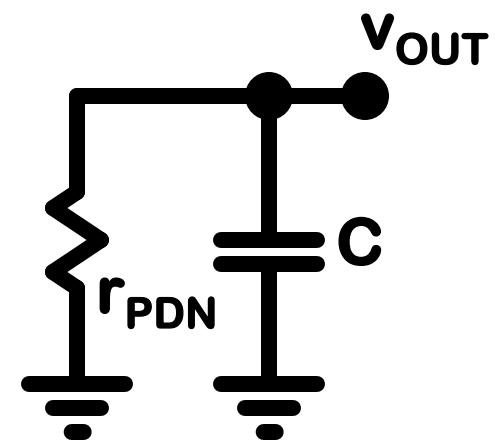

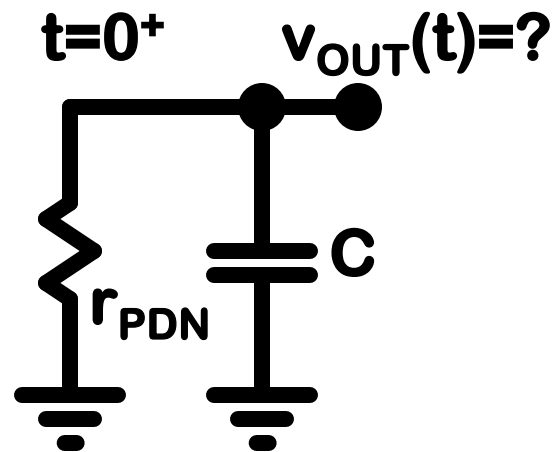
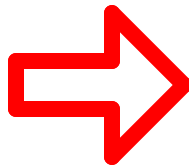
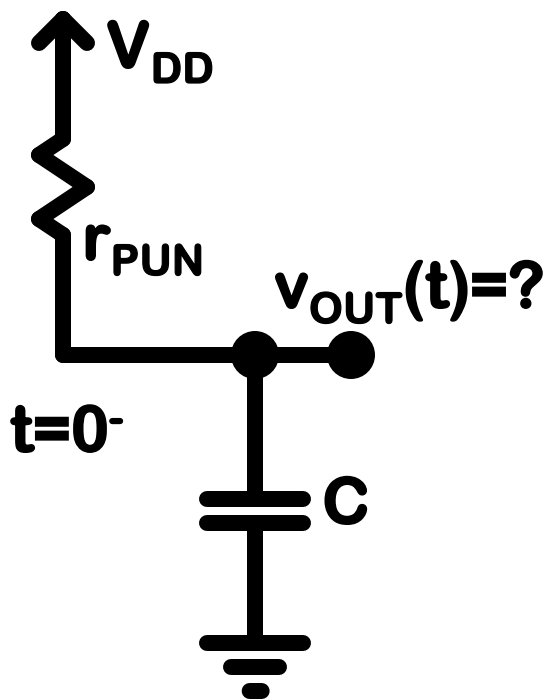
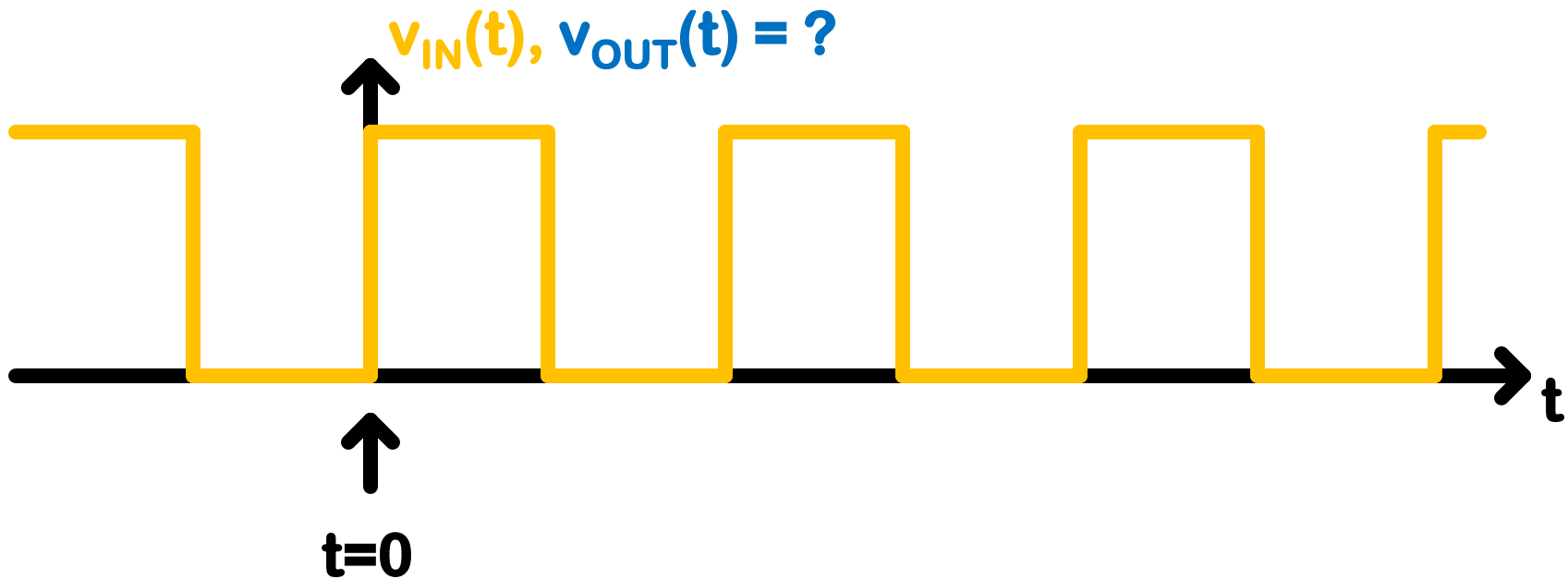

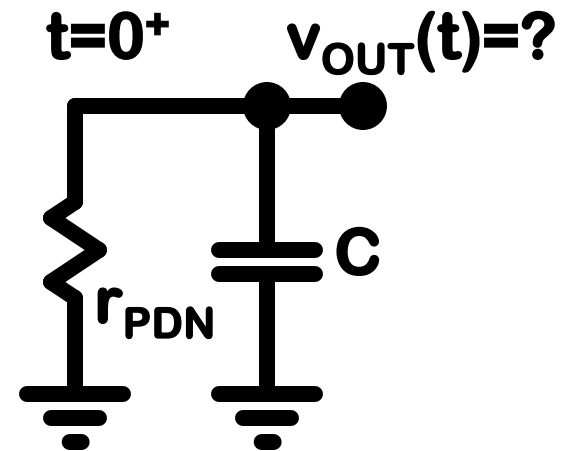
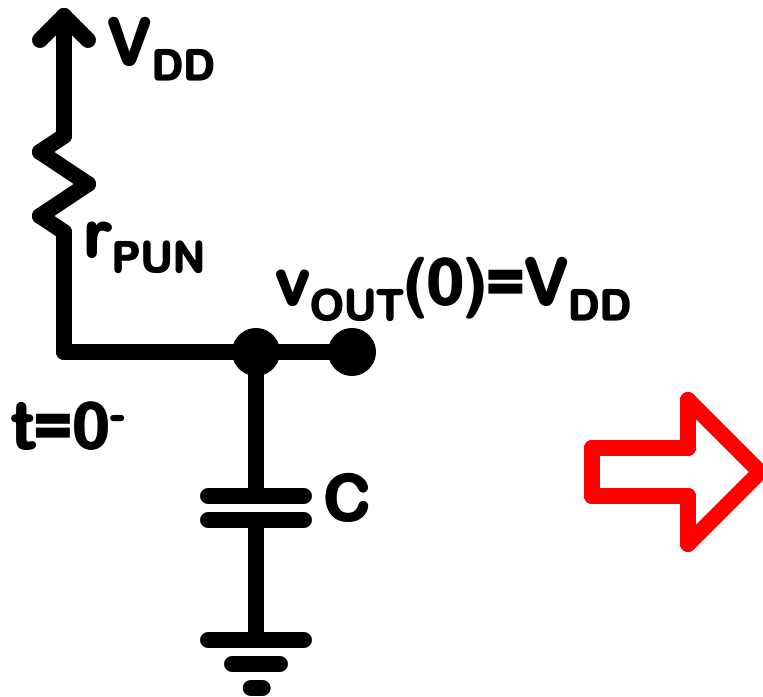
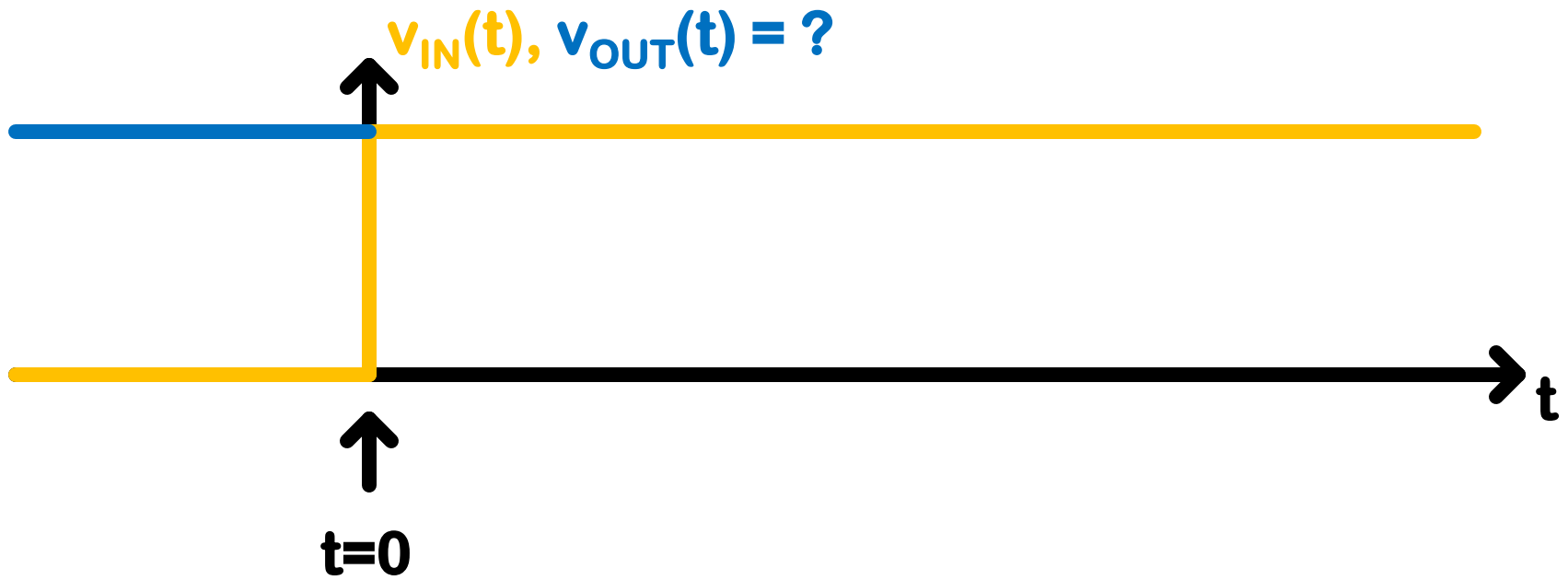

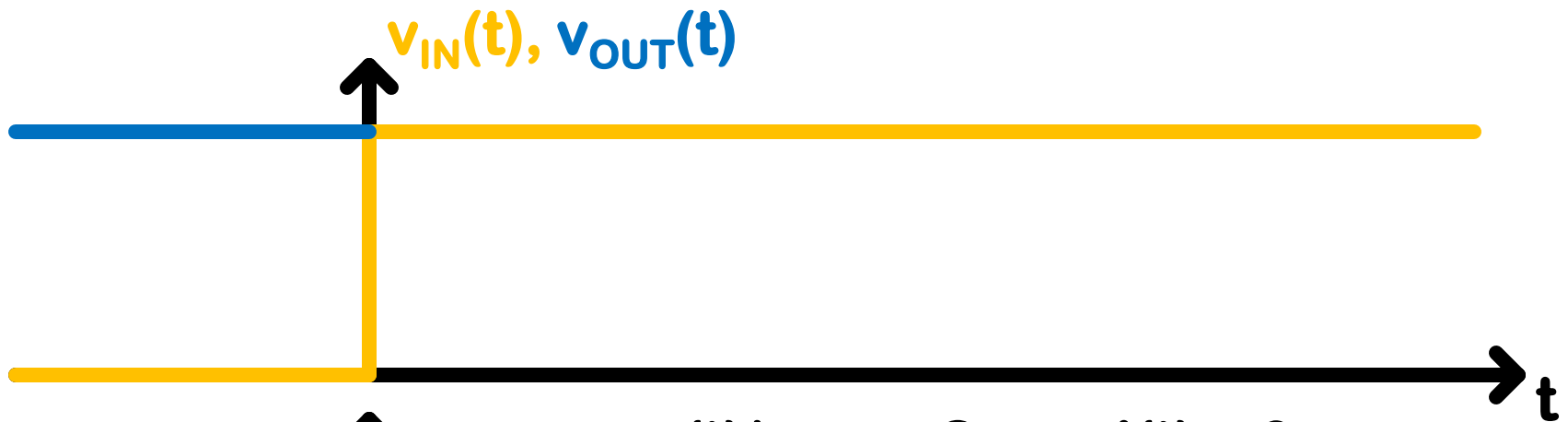

$t=0$

$$v_{OUT}(t)/r_{PDN} + C \cdot v_{OUT}'(t) = 0$$

$$v_{OUT}(t) = A_1 \cdot \exp(-t/(r_{PDN} \cdot C)) + A_2$$

$$v_{OUT}(0) = V_{DD}, \quad v_{OUT}(\infty) = 0$$

$$v_{OUT}(t) = V_{DD} \cdot \exp(-t/(r_{PDN} \cdot C))$$

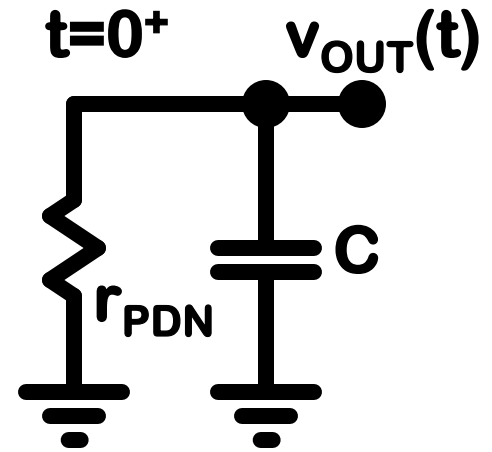
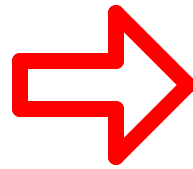
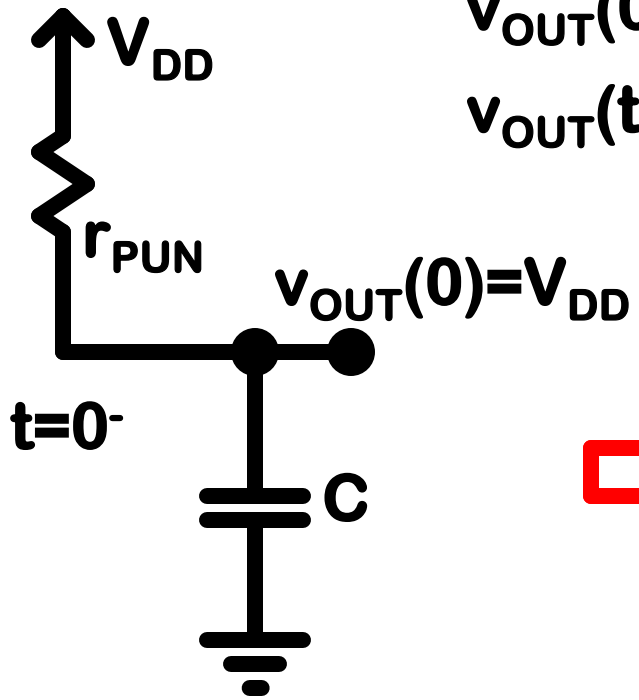

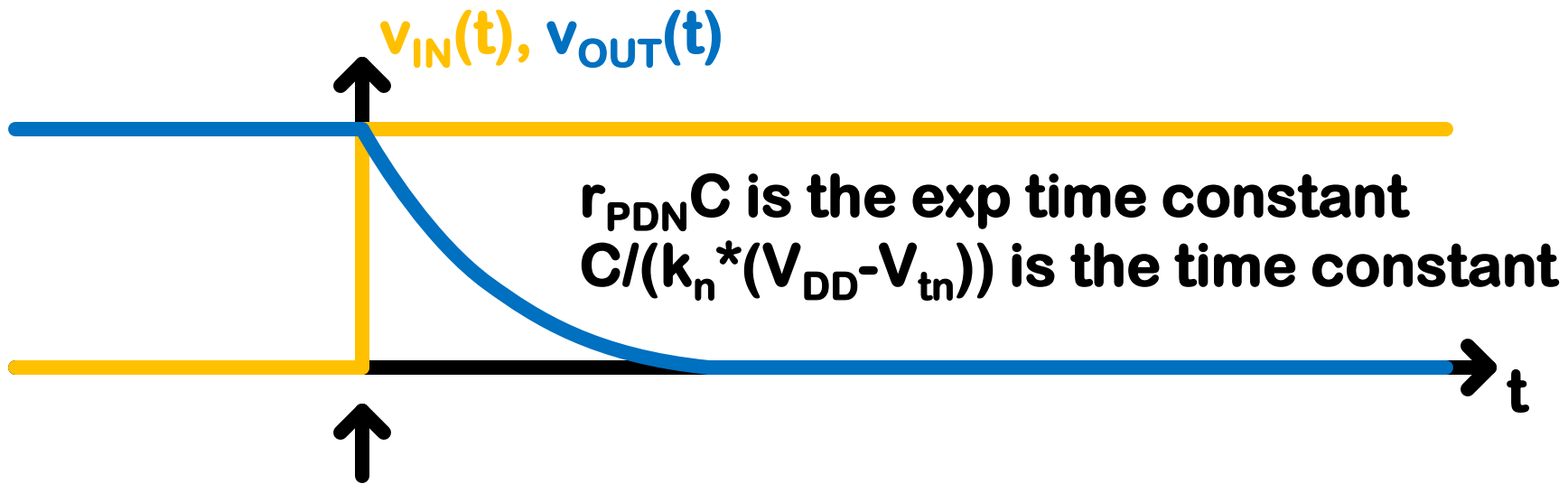

$t=0$

$v_{OUT}(t) = V_{DD}, \quad t < 0$

$v_{OUT}(t) = V_{DD} \cdot \exp(-t/(r_{PDN} \cdot C)) \quad t > 0$

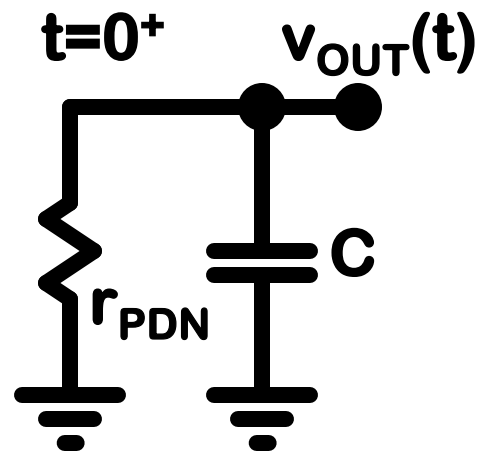
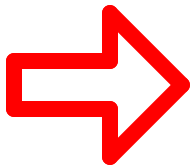
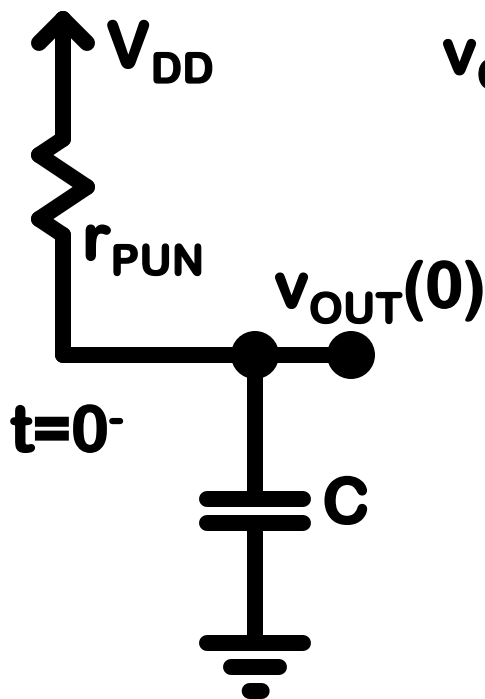

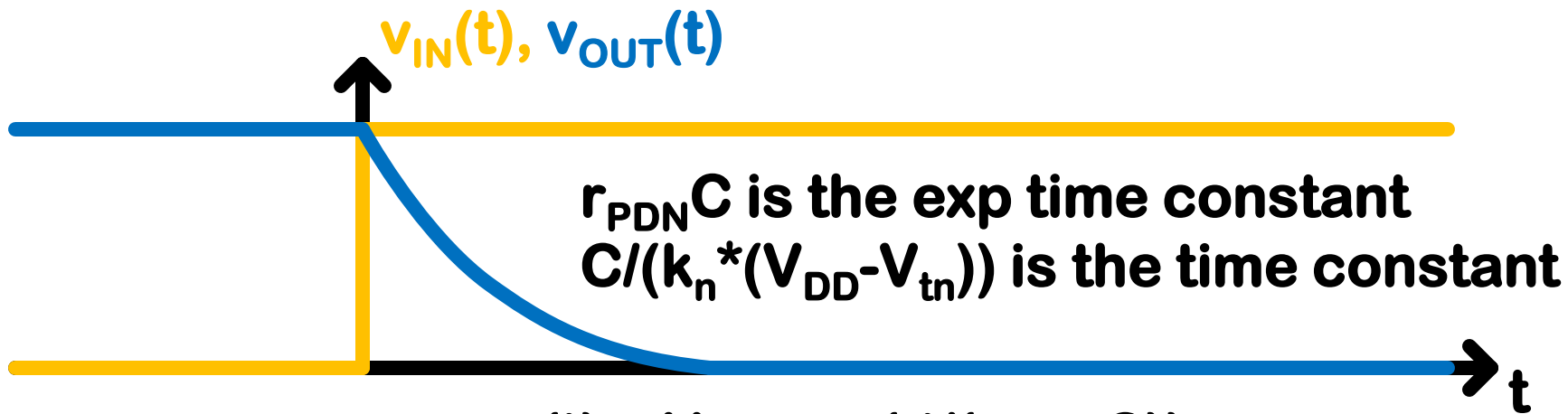

$$v_{OUT}(t) = V_{DD} \cdot \exp(-t/(r_{PDN} \cdot C))$$

$$i_r = v_{OUT}/r_{PDN} = (V_{DD}/r_{PDN}) \cdot \exp(-t/(r_{PDN} \cdot C))$$

$$P_{PDN} = v_{OUT}^2/r_{PDN}$$

$$P_{PDN} = (V_{DD}^2/r_{PDN}) \cdot \exp(-2t/(r_{PDN} \cdot C))$$

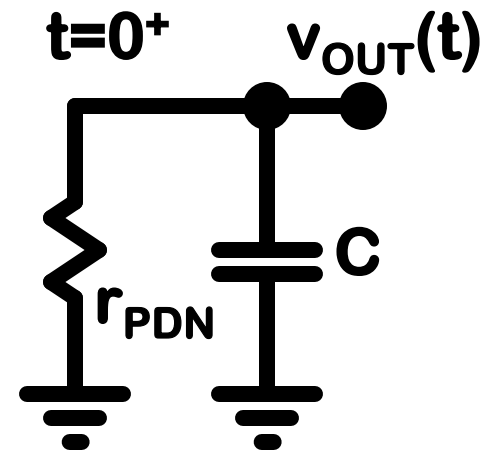
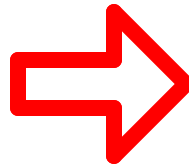
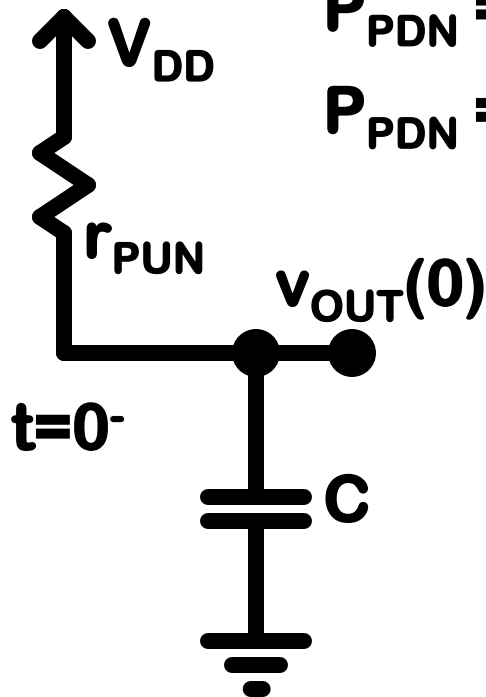

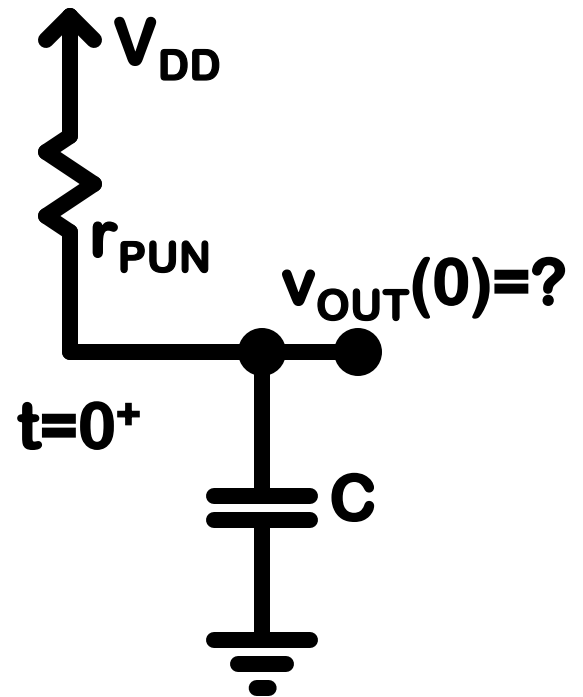
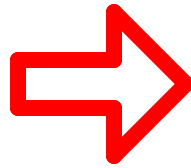
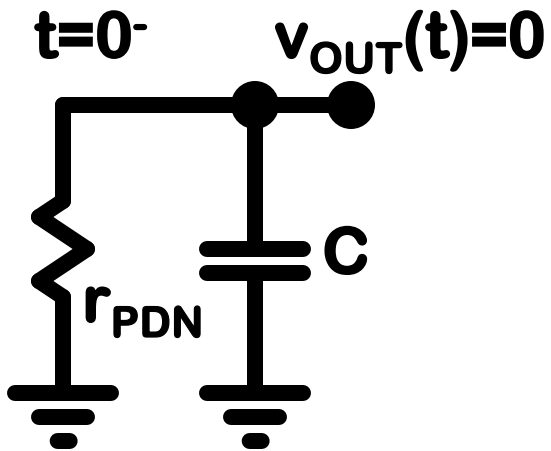
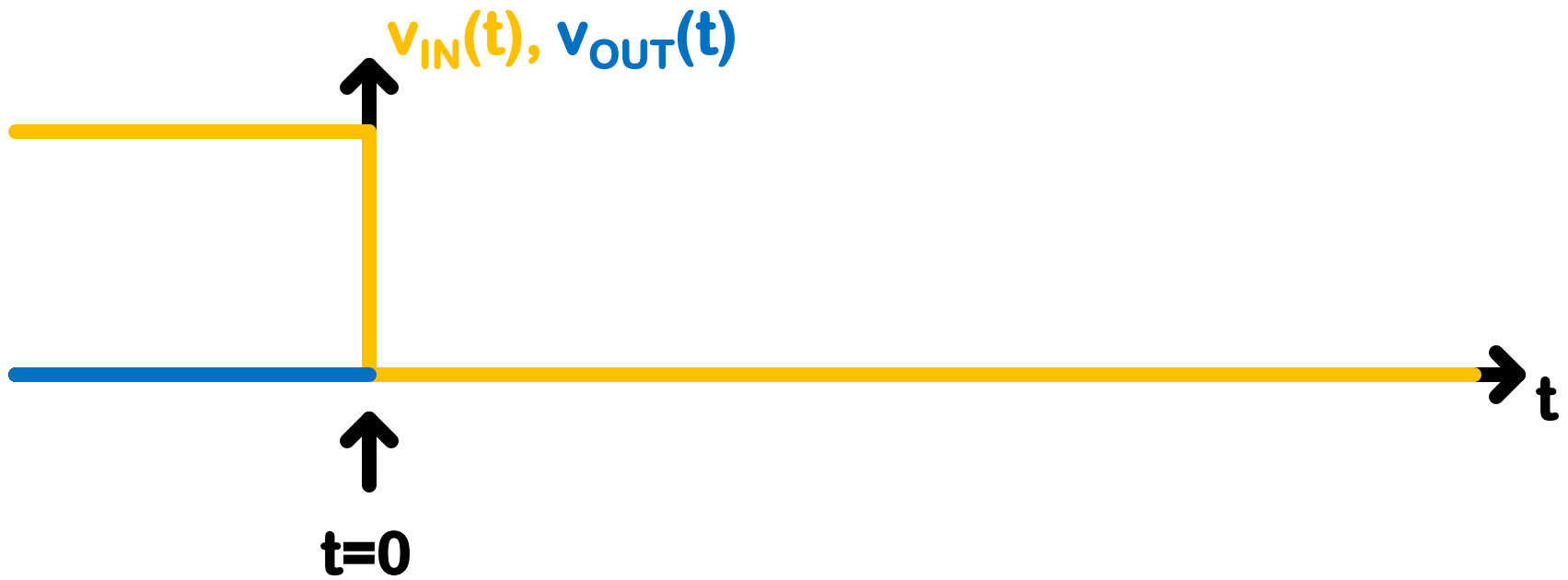

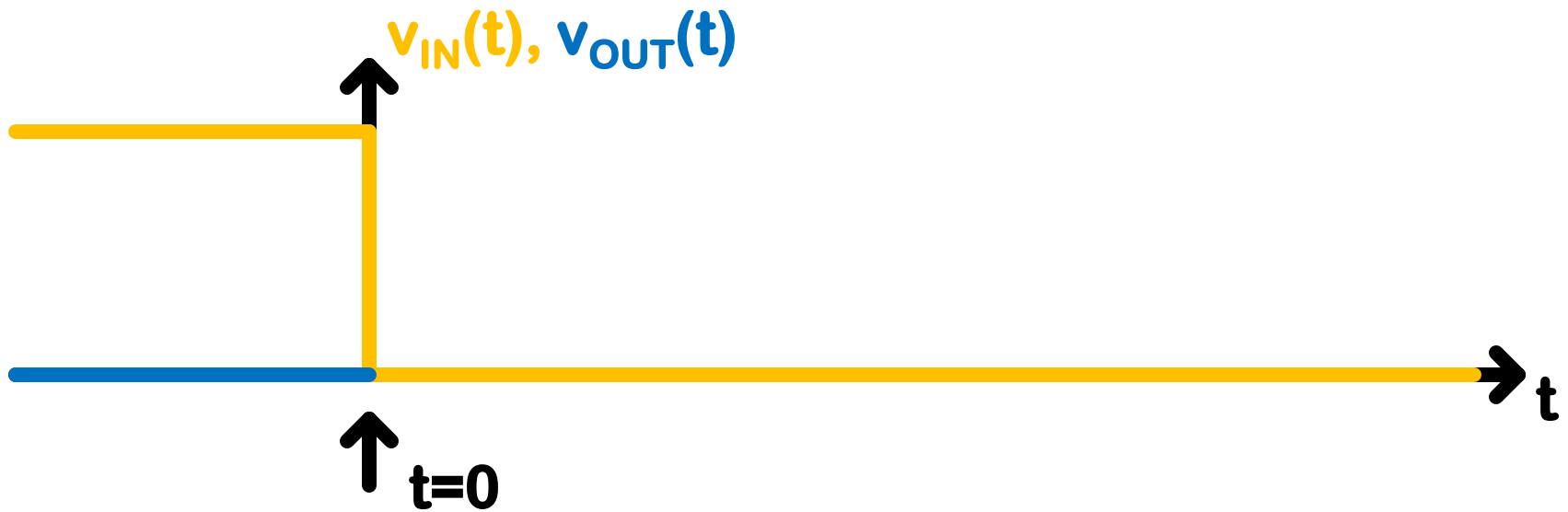

$$v_{OUT}(t) = 0, \quad t < 0$$

$$v_{OUT}(t) = V_{DD} - V_{DD} \cdot \exp(-t/(r_{PUN} \cdot C)) \quad t > 0$$

$$t < 0$$

$$t > 0$$

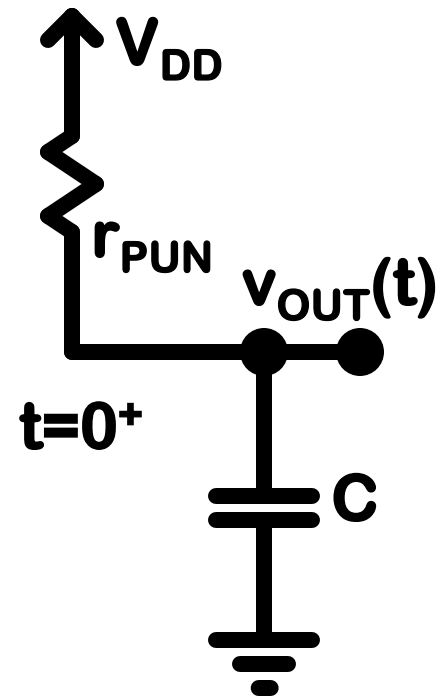
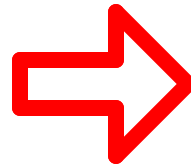
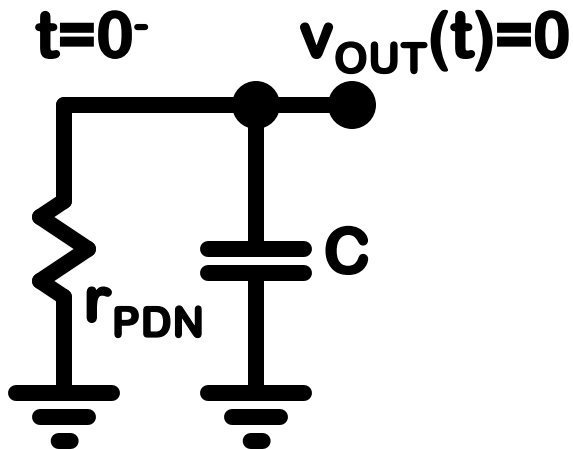

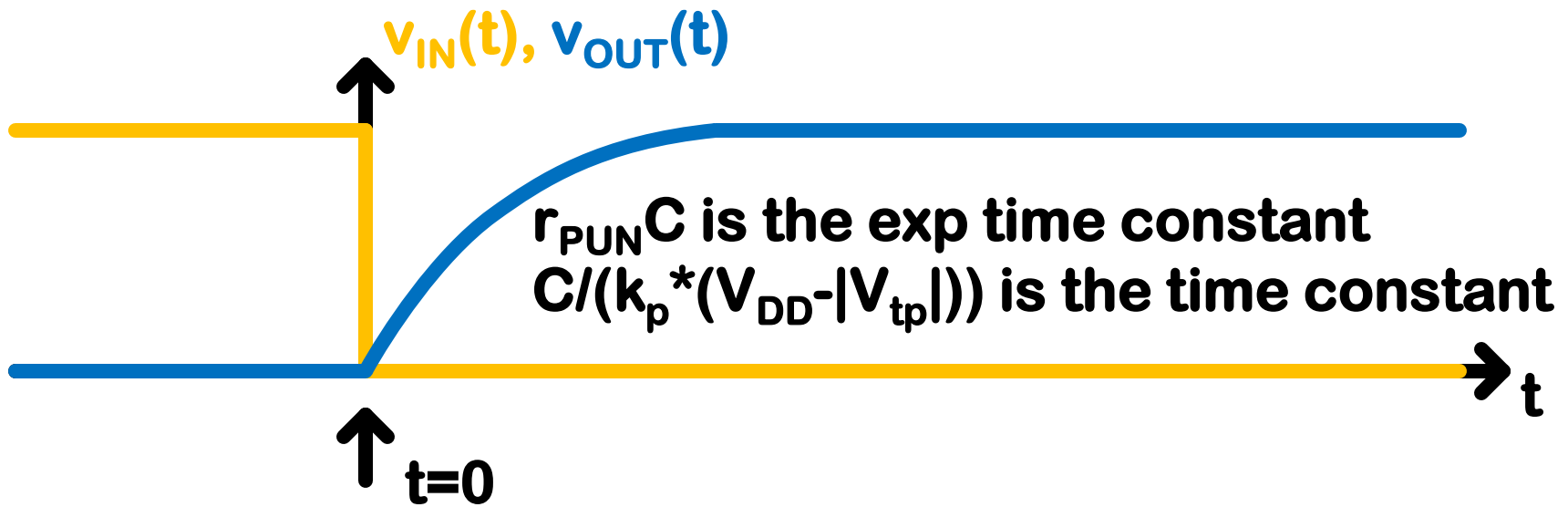

$$v_{OUT}(t) = 0, \quad t < 0$$

$$v_{OUT}(t) = V_{DD} - V_{DD} \cdot \exp(-t/(r_{PUN} \cdot C)) \quad t > 0$$

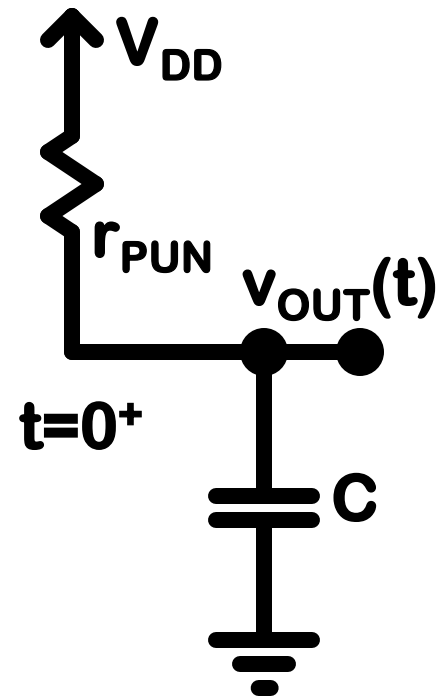
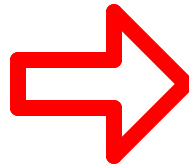
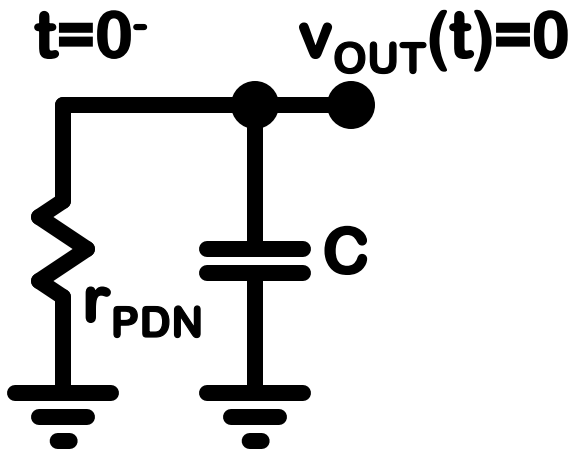

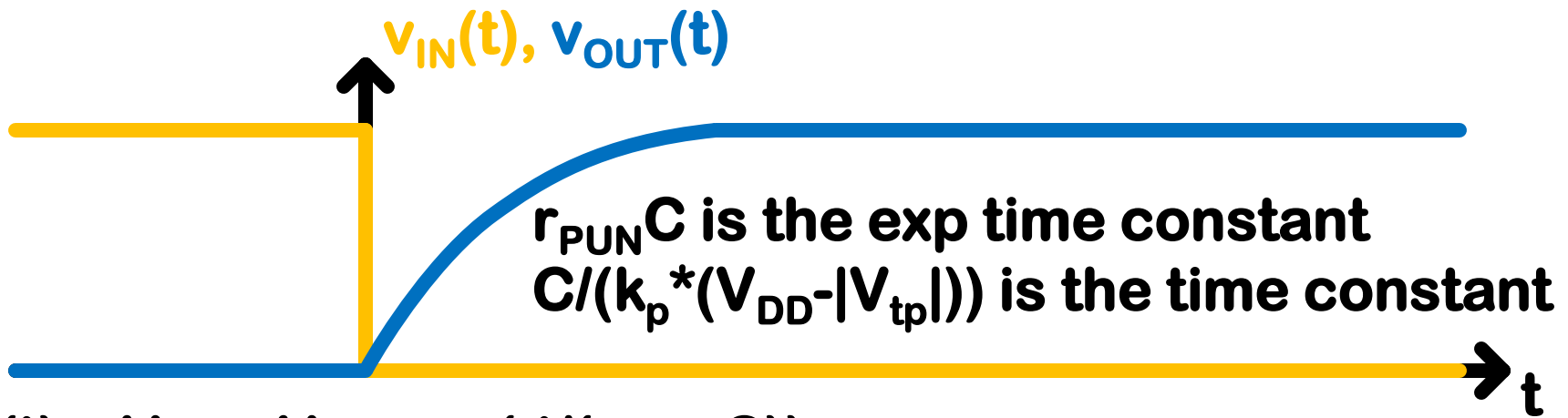

$$v_{OUT}(t) = V_{DD} - V_{DD} \cdot \exp(-t/(r_{PUN} \cdot C))$$

$$i_r = (V_{DD} - v_{OUT})/r_{PUN} = (V_{DD}/r_{PUN}) \cdot \exp(-t/(r_{PUN} \cdot C))$$

$$P_{PUN} = (V_{DD}^2/r_{PUN}) \cdot \exp(-2t/(r_{PUN} \cdot C))$$

$$P_{SUPPLY} = (V_{DD}^2/r_{PUN}) \cdot \exp(-t/(r_{PUN} \cdot C))$$

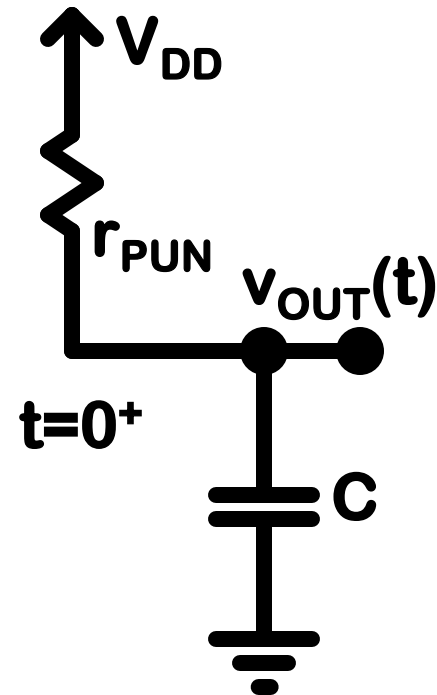
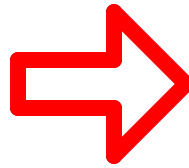
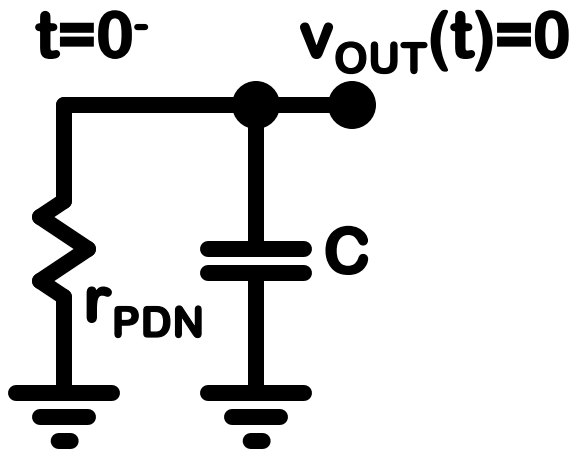

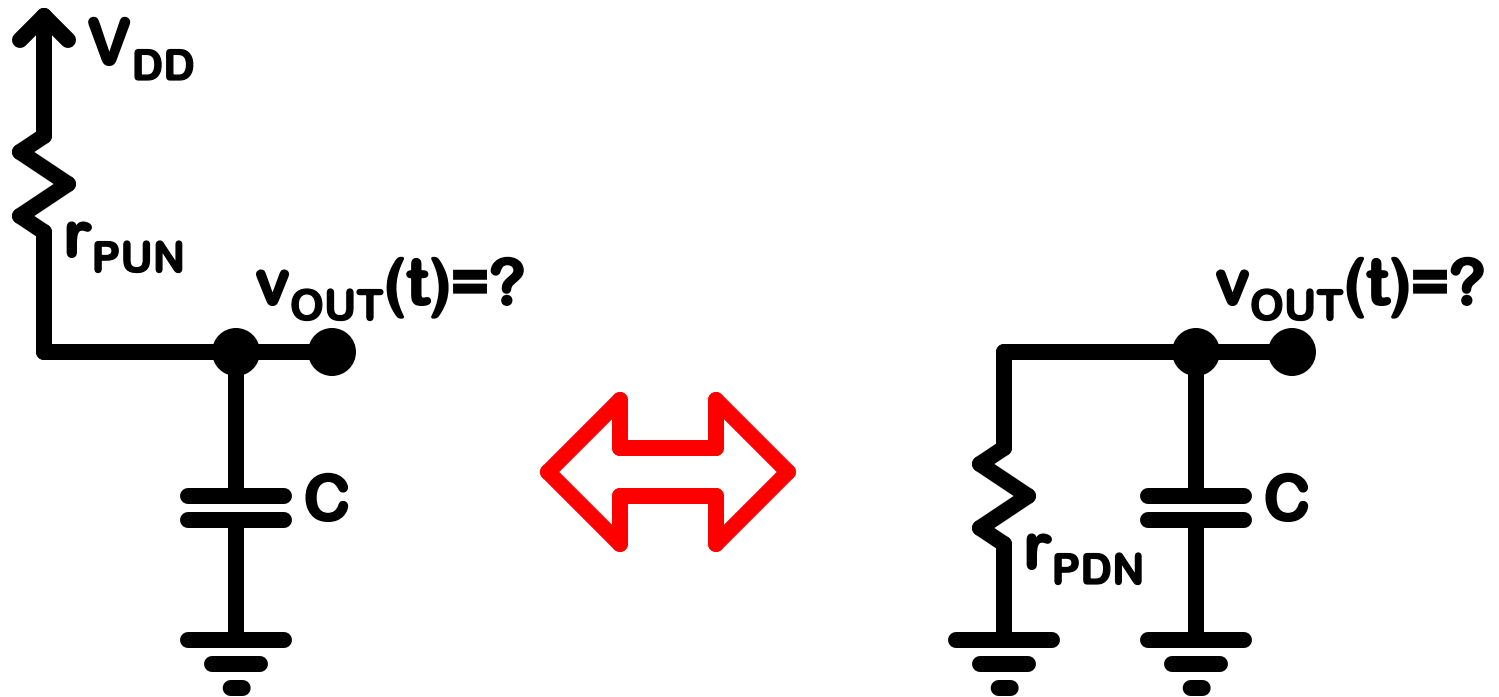
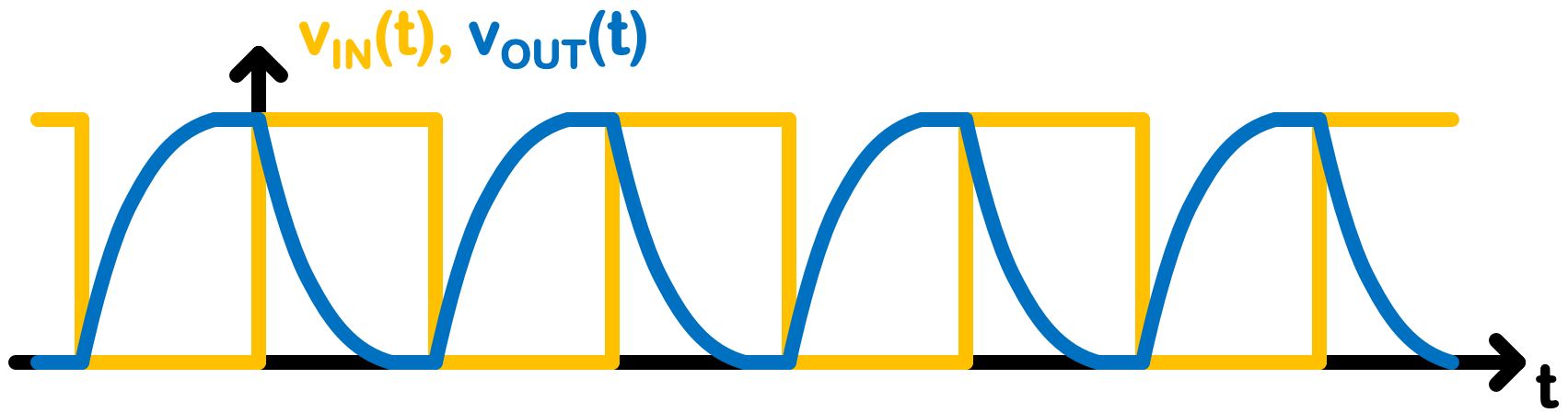

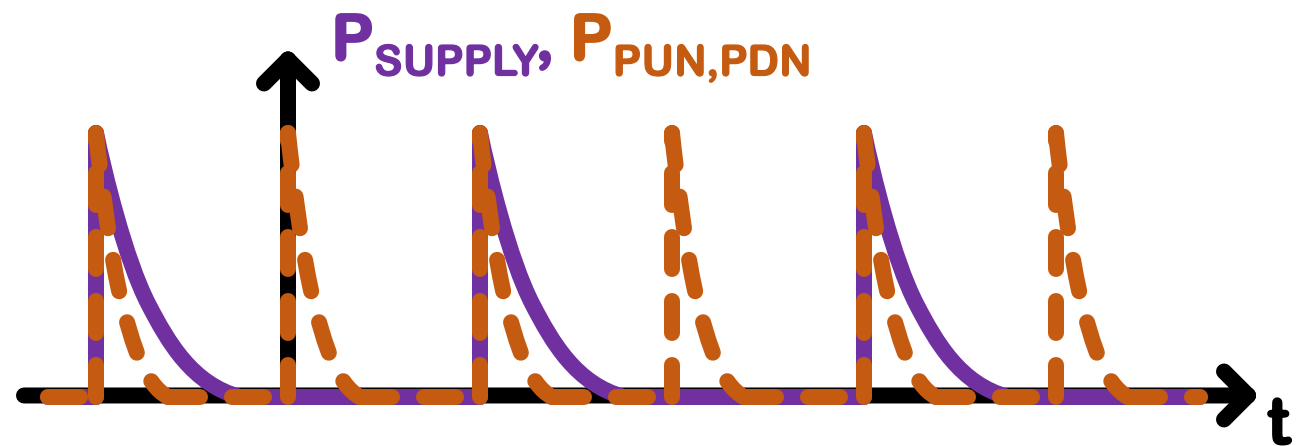
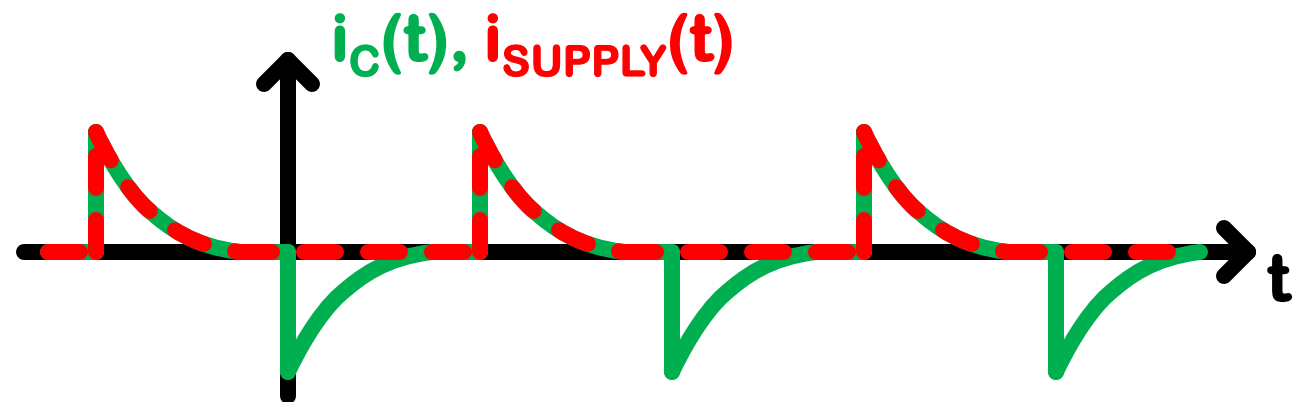
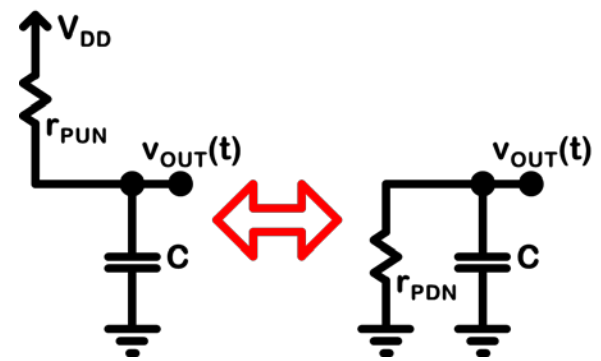
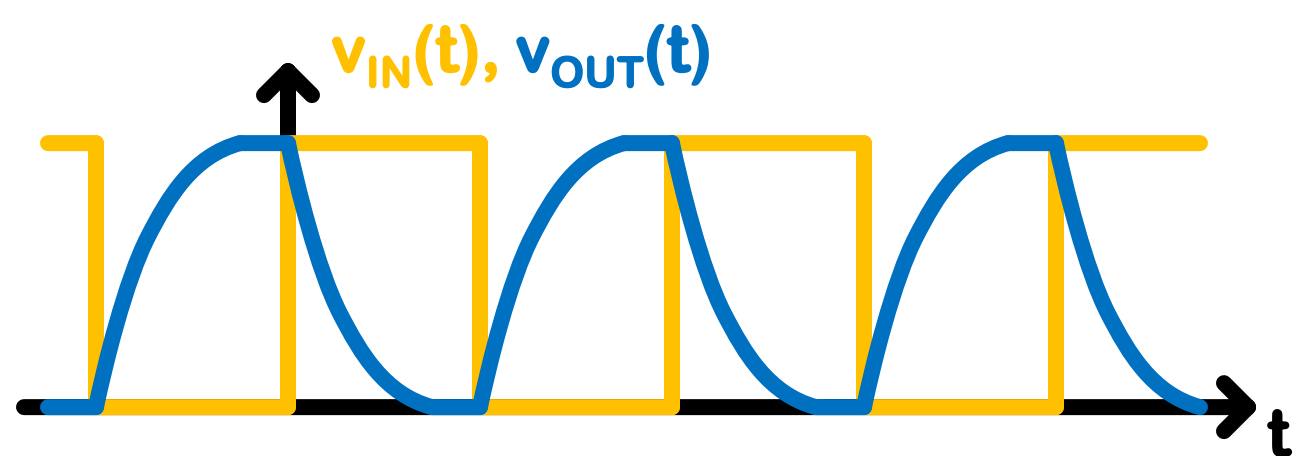

$v_{IN}(t), v_{OUT}(t)$

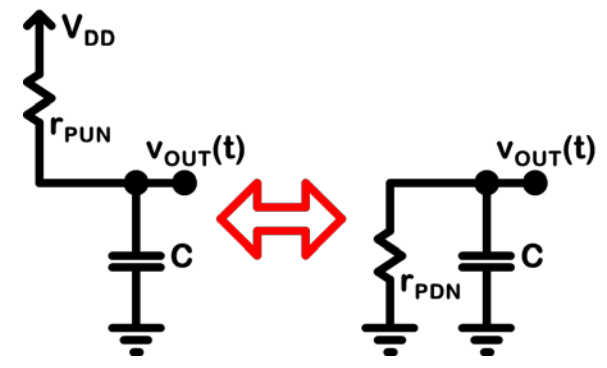
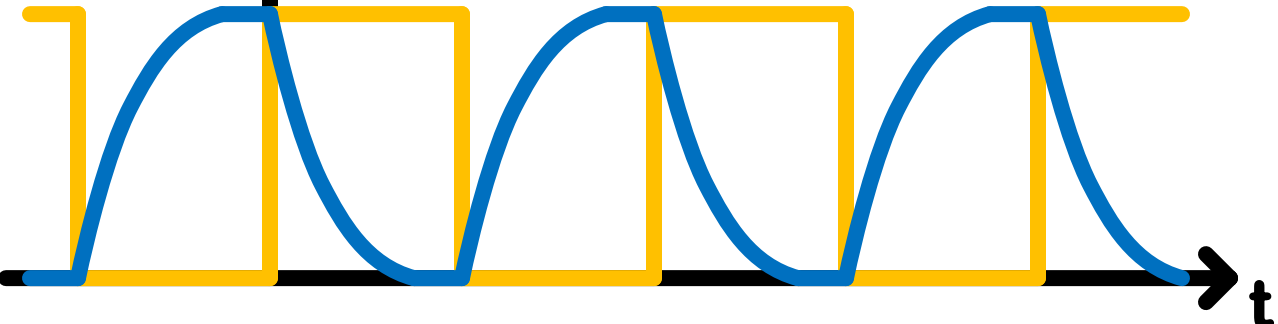

$$P_{SUPPLY} = (V_{DD}^2/r_{PUN}) \cdot \exp(-t/(r_{PUN} \cdot C))$$

$$P_{AVG} = (1/T) \int_T (V_{DD}^2/r_{PUN}) \cdot \exp(-t/(r_{PUN} \cdot C)) dt$$

$$P_{AVG} = - (1/T) r_{PUN} \cdot C (V_{DD}^2/r_{PUN}) \cdot \exp(-t/(r_{PUN} \cdot C)) \Big|_0 \text{ to } T$$

$$P_{AVG} = (1/T) C (V_{DD}^2) \quad \text{if} \quad r_{PUN} C \ll T$$

$P_{SUPPLY}, P_{PUN,PDN}$

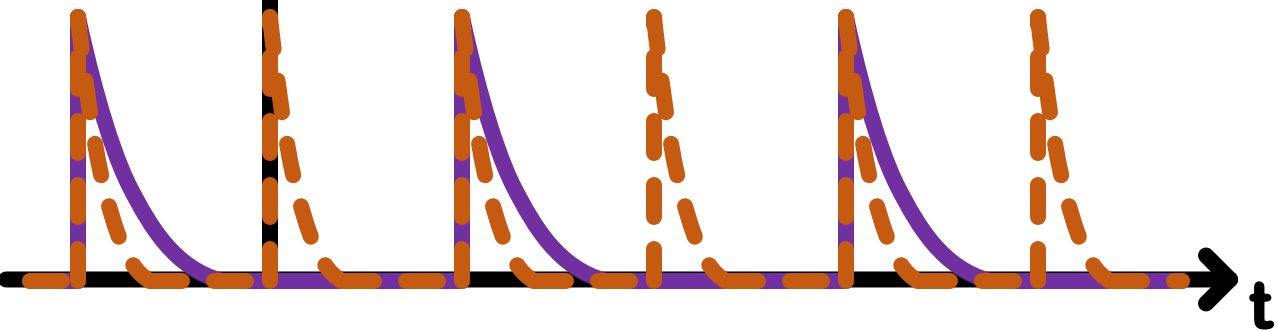

$$P_{AVG} = f \cdot C \cdot V_{DD}^2$$

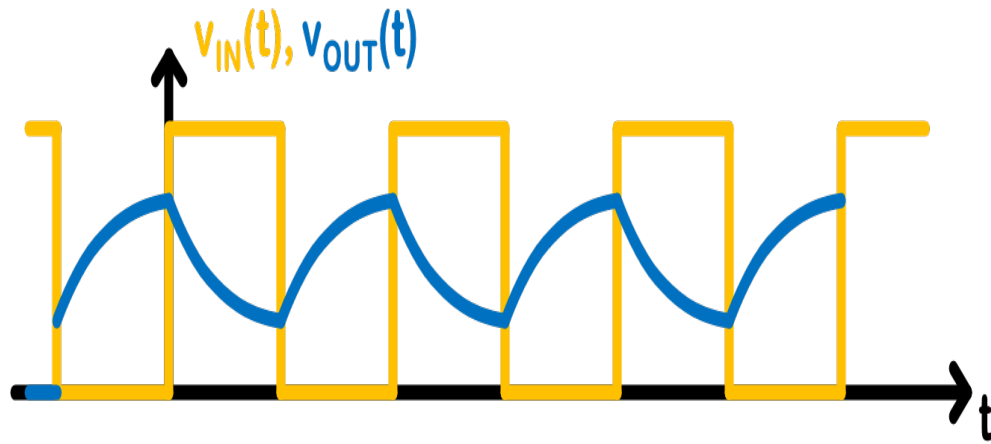
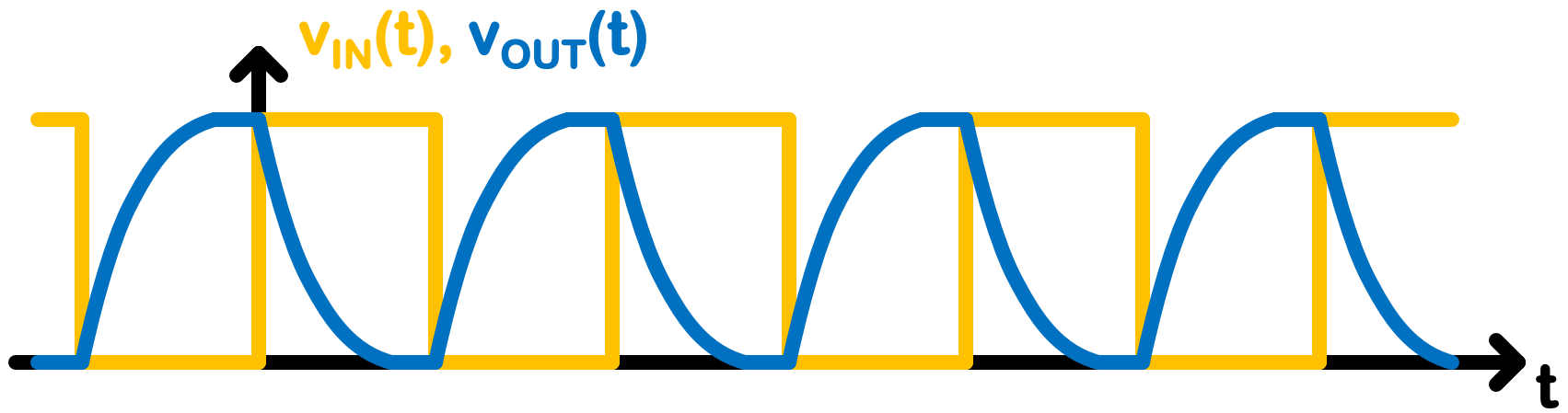

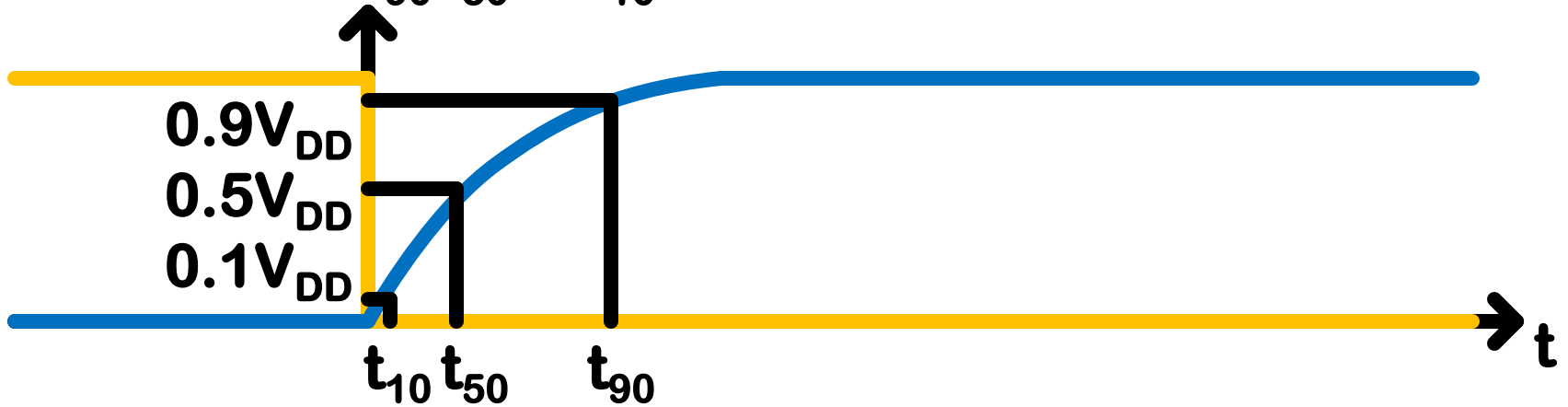
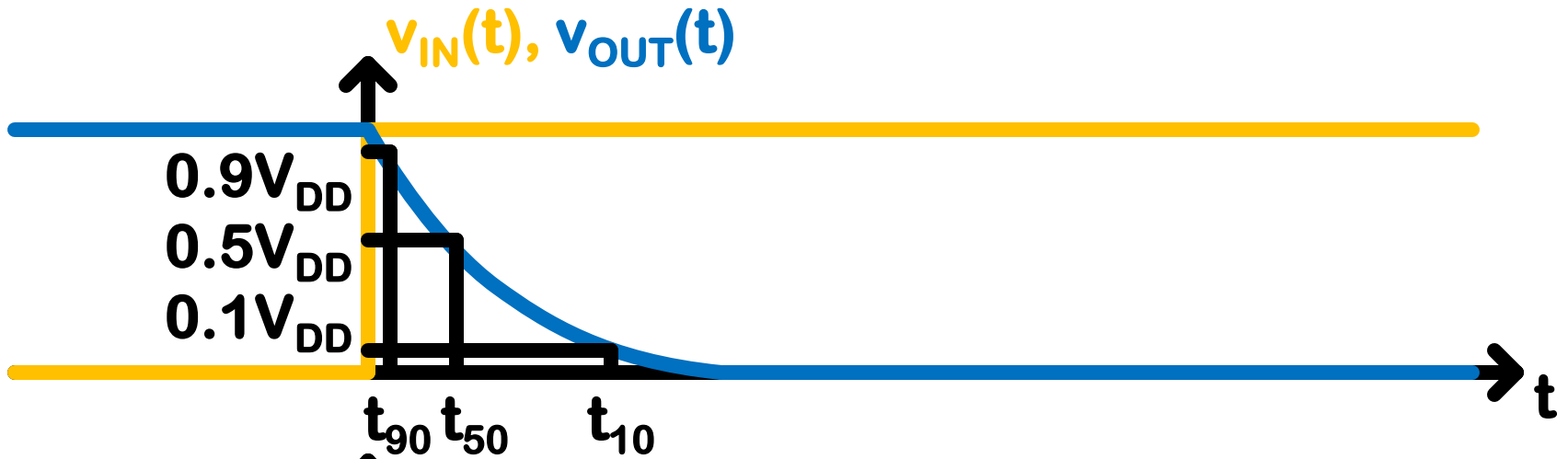

$\tau_{PHL} = t_{50}$  on top plot

$\tau_{PLH} = t_{50}$  on bottom plot

$\tau_{THL} = t_{10} - t_{90}$  on top plot

$\tau_{TLH} = t_{90} - t_{10}$  on bottom plot

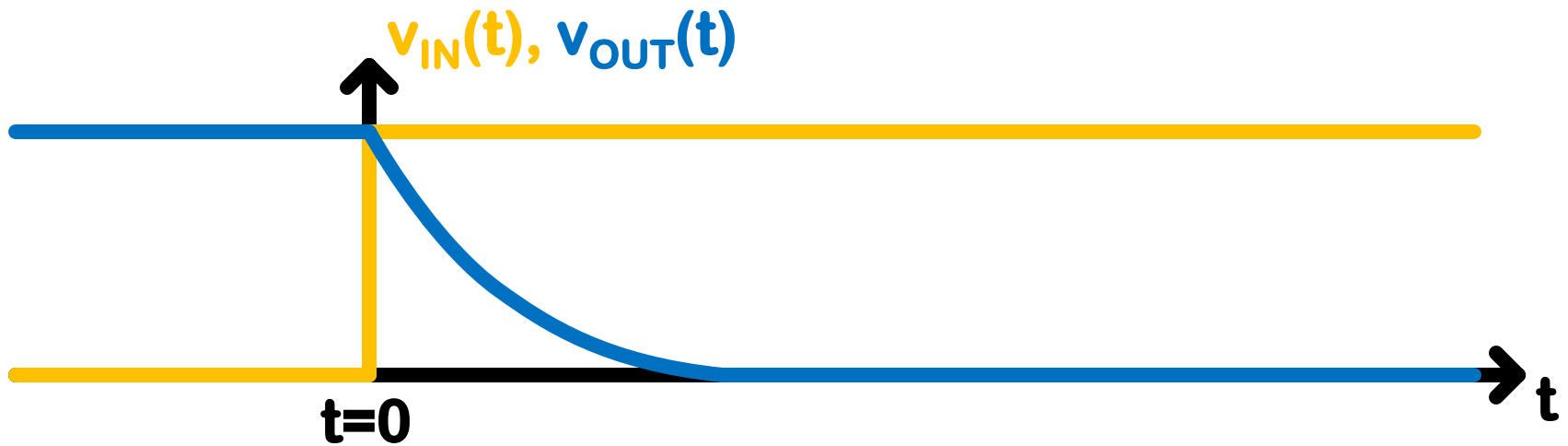

$$v_{OUT}(t_{50}) = V_{DD} \cdot \exp(-t_{50}/(r_{PDN} \cdot C)) = V_{DD}/2$$

$$-t_{50}/(r_{PDN} \cdot C) = \ln(1/2)$$

$$t_{50} = r_{PDN} \cdot C \cdot \ln(2)$$

$$-t_{10}/(r_{PDN} \cdot C) = \ln(1/10)$$

$$t_{10} = r_{PDN} \cdot C \cdot \ln(10)$$

$$-t_{90}/(r_{PDN} \cdot C) = \ln(9/10)$$

$$t_{90} = r_{PDN} \cdot C \cdot \ln(10/9)$$

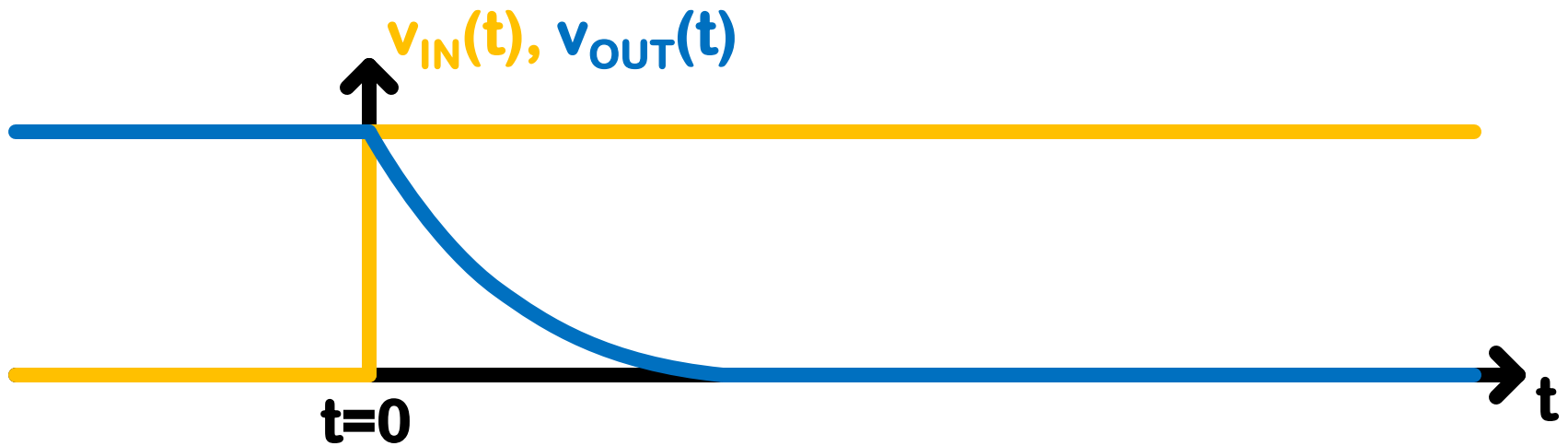

$$\tau_{PHL} = t_{50} = r_{PDN} \cdot C \cdot \ln(2)$$

$$\tau_{THL} = t_{10} - t_{90} = r_{PDN} \cdot C \cdot \ln(10) - r_{PDN} \cdot C \cdot \ln(10/9)$$

$$\tau_{THL} = r_{PDN} \cdot C \cdot (\ln(10) - \ln(10/9)) = r_{PDN} \cdot C \cdot \ln(10 \cdot 9/10)$$

$$\tau_{PHL} = r_{PDN} \cdot C \cdot \ln(2)$$

$$\tau_{THL} = r_{PDN} \cdot C \cdot \ln(9)$$

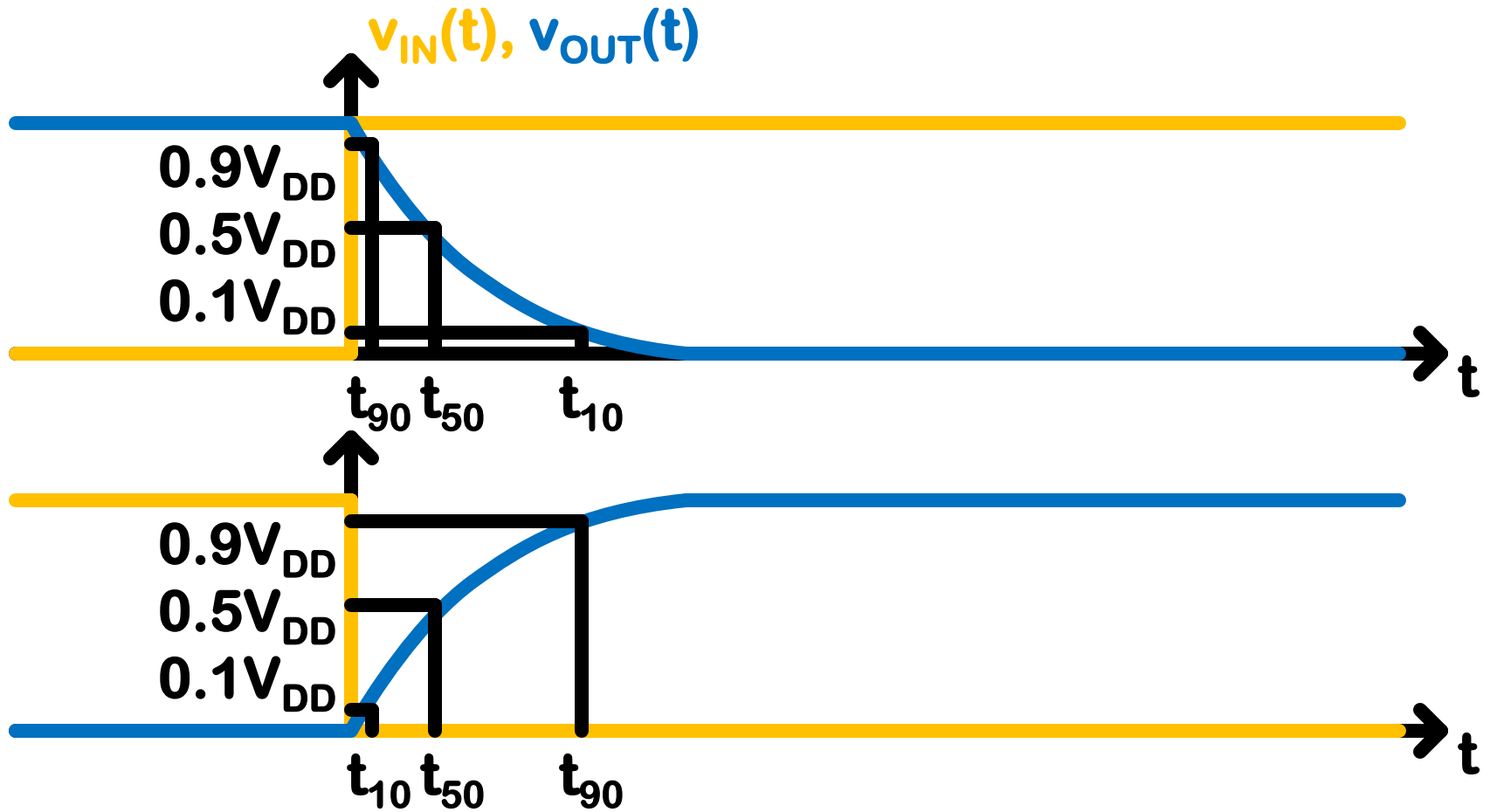

$$\tau_{PHL}, \tau_{PLH} = r_{PDN, PUN} \cdot C \cdot \ln(2)$$

$$\tau_{THL}, \tau_{TLH} = r_{PDN, PUN} \cdot C \cdot \ln(9)$$

**This is for the simple model of a resistor and capacitor.**

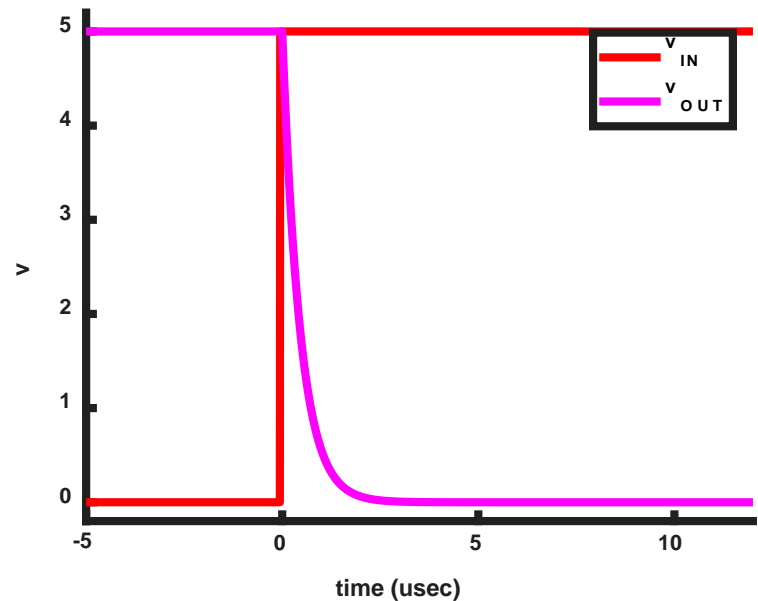
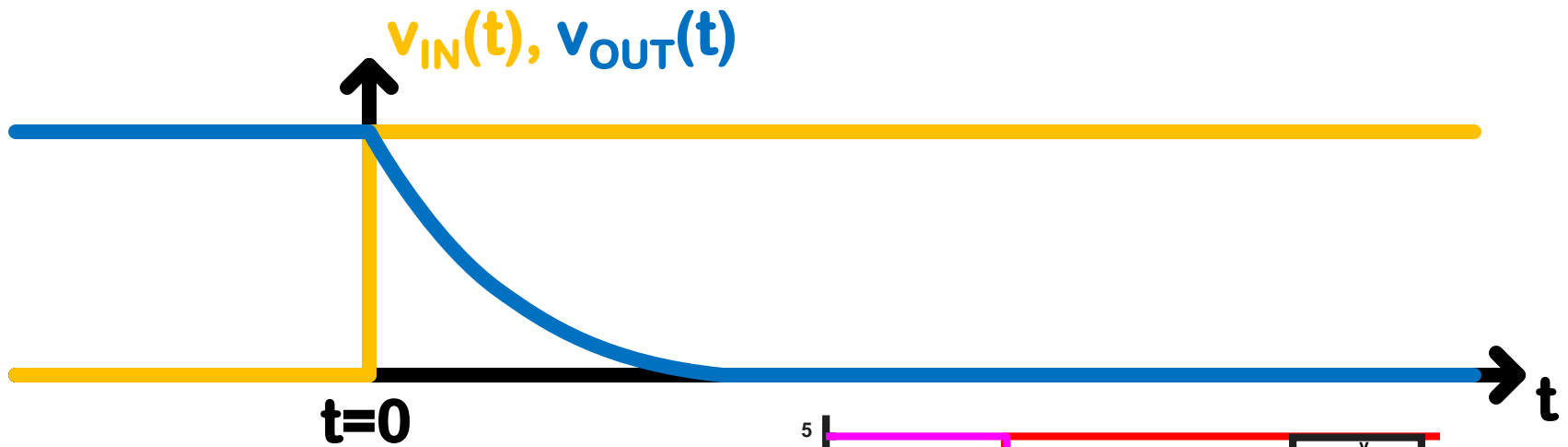

$$v_{OUT}(t) = V_{DD} \cdot \exp(-t/(r_{PDN} \cdot C))$$

$$k_n = 130 \text{ mA/V}$$

$$V_{tn} = 1.62 \text{ V}$$

$$V_{DD} = 5 \text{ V}$$

$$C = 200 \text{ nF}$$

$$r_{PDN} = r_{DS} = 1/ (.130 * (5 - 1.62)) = 2.27 \ \Omega$$

$$r_{PDN} \cdot C = 454 \text{ nsec}$$

$$v_{OUT}(t) = 5 \cdot \exp(-t/(454 \times 10^{-9}))$$

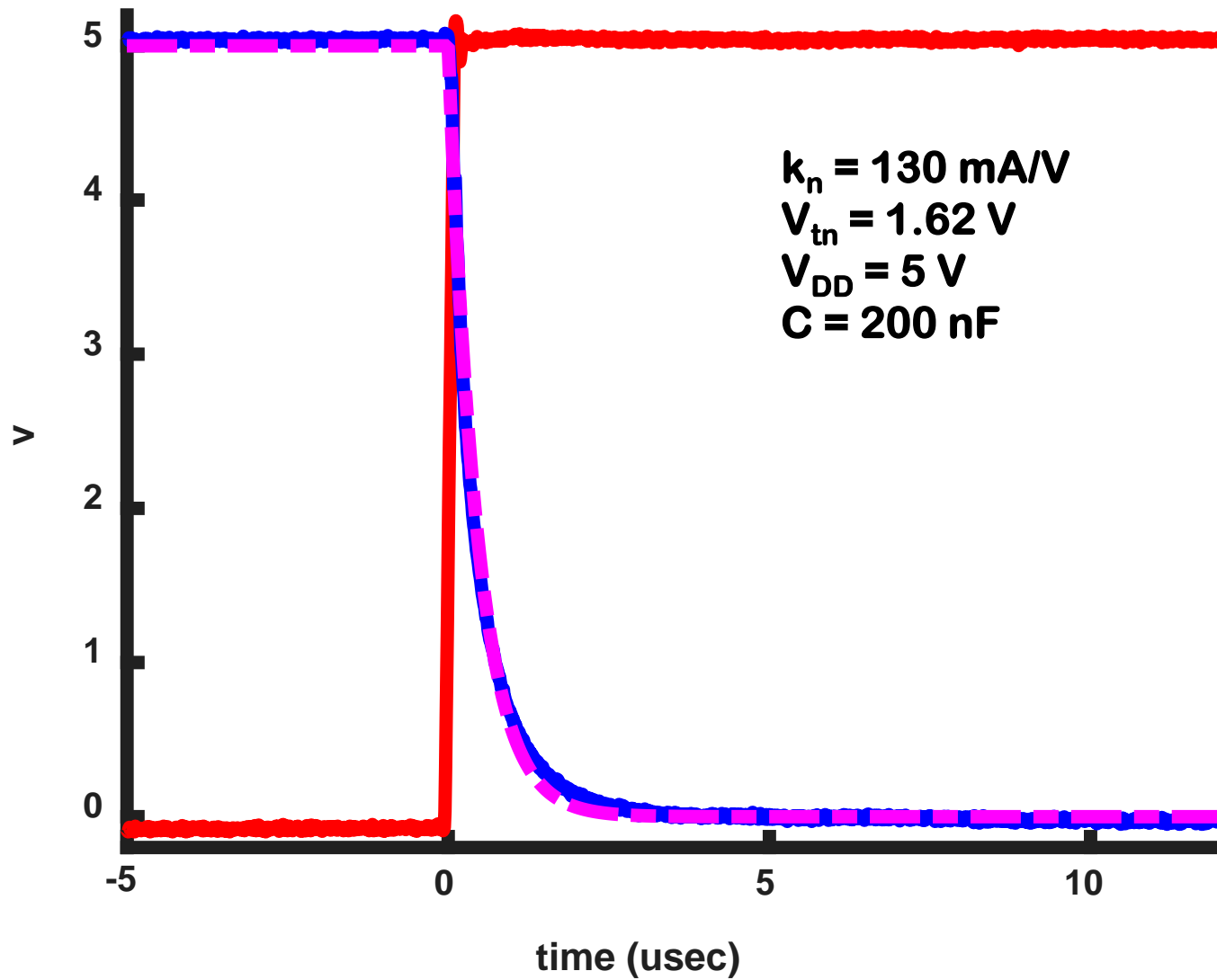

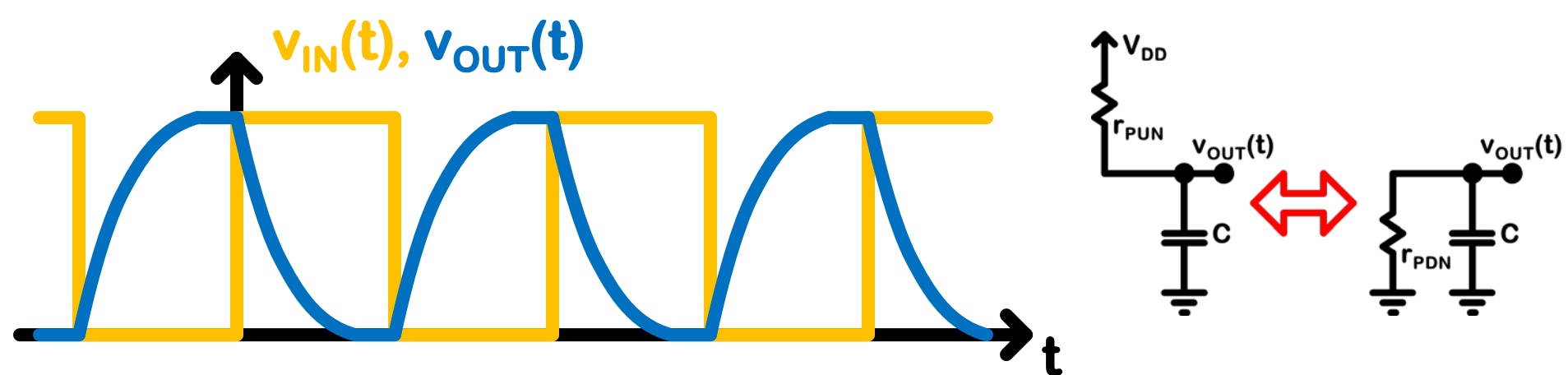

$$P_{AVG} = f \cdot C \cdot V_{DD}^2$$

$$\tau_{PHL}, \tau_{PLH} = r_{PUN, PUN} \cdot C \cdot \ln(2)$$

$$\tau_{THL}, \tau_{TLH} = r_{PDN, PUN} \cdot C \cdot \ln(9)$$

For this model the minimum clock period is proportional to  $\tau_{THL}$  or  $\tau_{TLH}$ .

$$f_{max} \sim 1/\tau_T \sim 1/(r_{PUN, PUN} \cdot C)$$

$$r_{SD, DS} = 1/(k'(W/L)(V_{DD} - V_t))$$

$v_{IN}(t), v_{OUT}(t)$

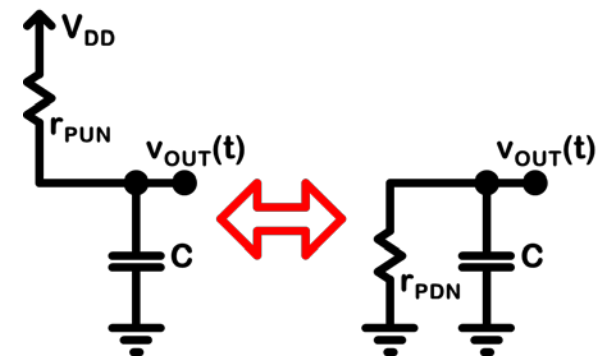
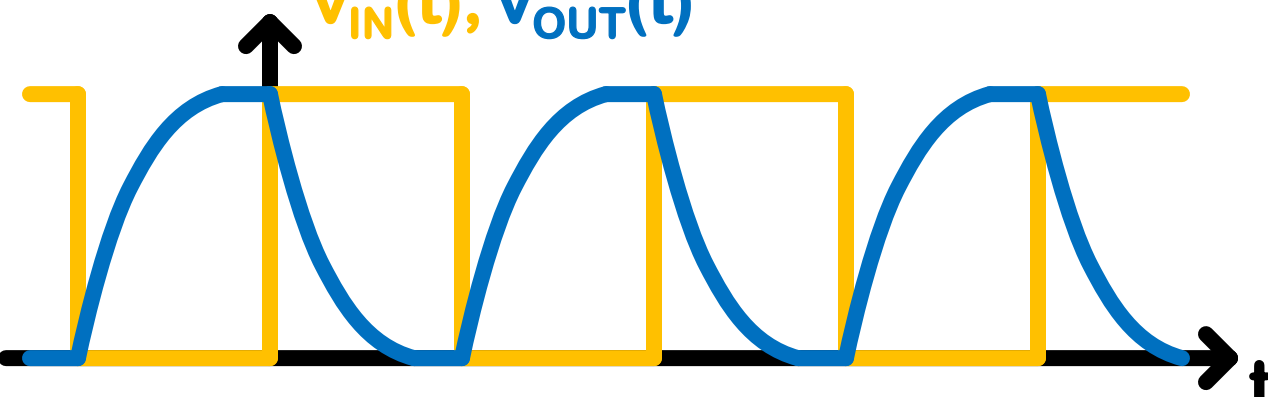

$P_{AVG} = N \cdot f \cdot C \cdot V_{DD}^2$

$f_{max} \sim (2/C) \cdot k' \cdot (W/L) \cdot (V_{DD} - V_t)$

$A = N \cdot W \cdot L$

**Performance ( $f_{max}$ ) vs. Power Dissipation ( $P_D$ ) vs. Area/Number ( $A, N$ )**  
(assume always operating at  $f_{max}$ )

1. Increase  $V_{DD}$  (Power vs  $f_{max}$ )

- $f_{max}$  goes up by  $V_{DD} - V_t$
- Power goes up by  $(V_{DD} - V_t) \cdot V_{DD}^2$

2. Increase  $W/L$  ( $f_{max}$  vs  $A$ )

- $f_{max}$  goes up by  $W$
- Power goes up by  $W$  (because of  $f_{max}$ )
- Uses more area on the IC

3. Find a better process that has

- Larger  $k'$
- Smaller  $C$ , but  $k' = \mu C_{ox}$ , so maybe higher mobility.
- Smaller  $V_t$

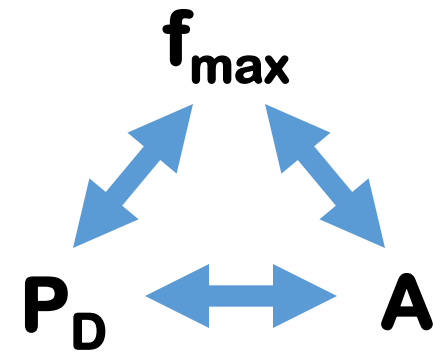

# CMOS Inverter

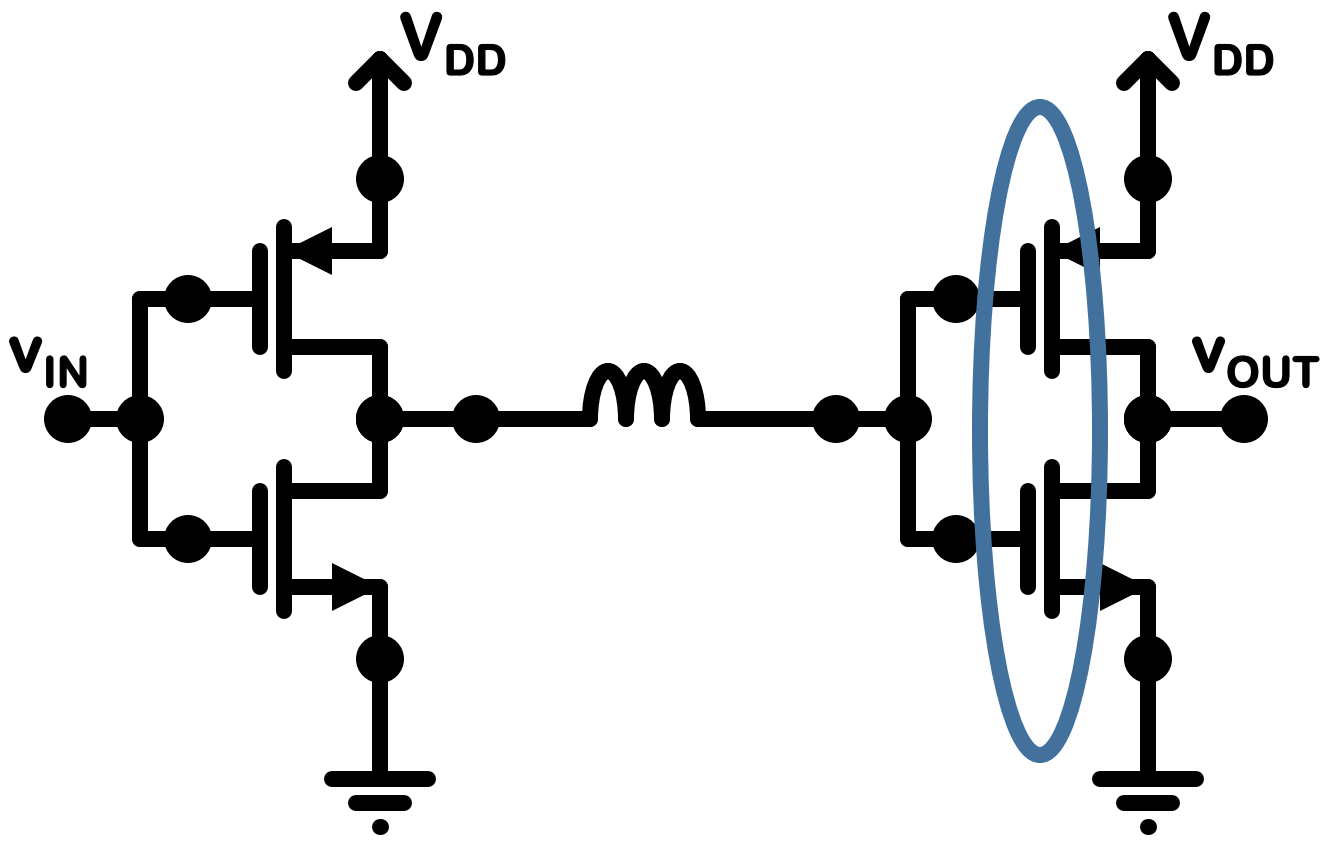

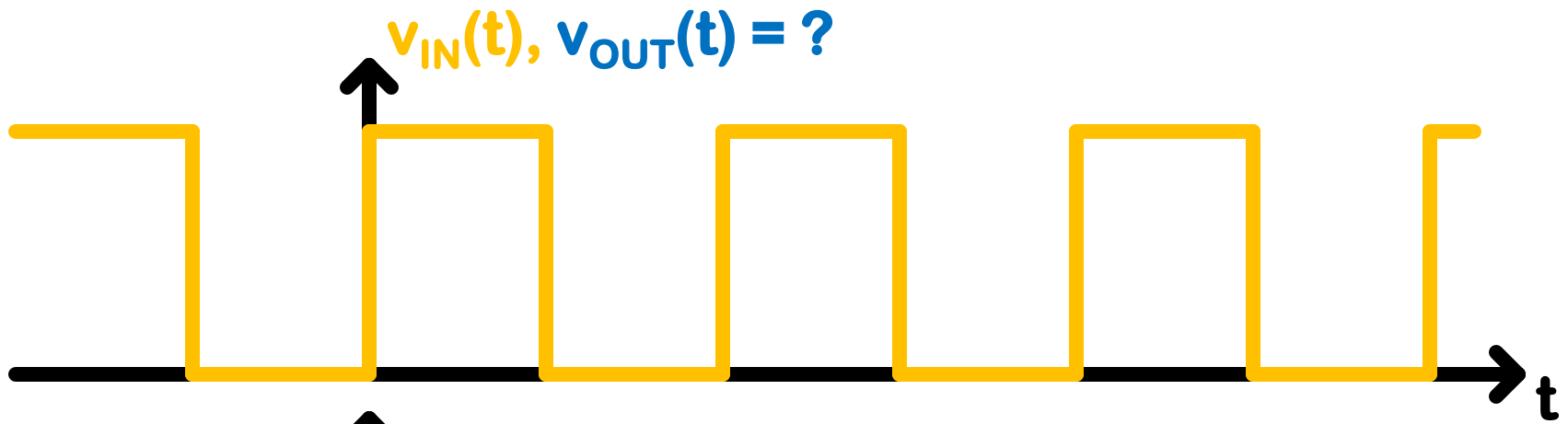

$t=0$

For this model, the output voltage would be a 2<sup>nd</sup> order differential equation.

- a. overdamped.
- b. underdamped (ringing)
- c. critically...

