

The ability of a MOSFET in saturation to control the current through the drain using a voltage between the gate and the source makes it possible produce large voltage swings if an appropriately large resistor is used.

In the NMOS common source circuit, the saturation mode (red section) transfer function is expressed as:

$$v_{OUT}(v_{IN}) = V_{DD} - 0.5 \cdot R_D \cdot k_n \cdot (v_{IN} - V_{tn})^2$$

Using values based off the circuit demo in class, we get

$$V_{DD} = 5 \text{ V}$$

$$R_D = 2 \text{ k}\Omega$$

$$k_n = 25 \text{ mA/V}^2$$

$$V_{tn} = 1.6 \text{ V}$$

$$v_{OUT}(v_{IN}) = 5 - 25 \cdot (v_{IN} - 1.6)^2$$

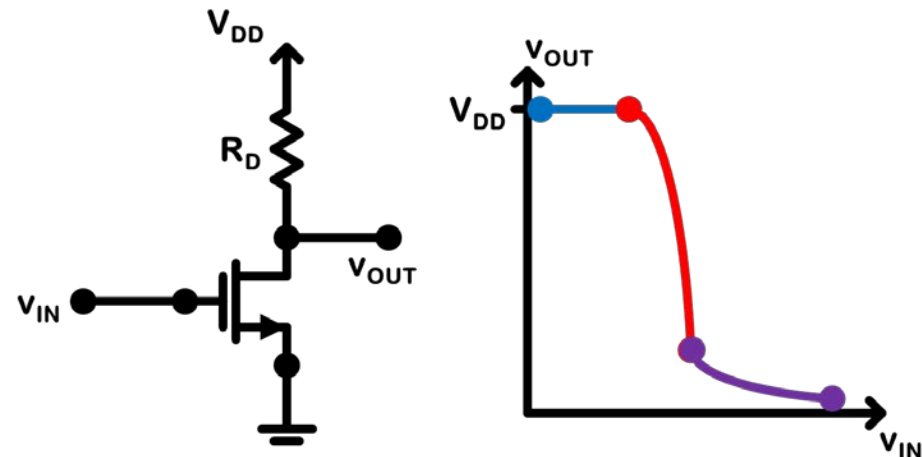

## Saturation mode transfer function:

$$v_{\text{OUT}}(v_{\text{IN}}) = 5 - 25 \cdot (v_{\text{IN}} - 1.6)^2$$

for an input

$$v_{\text{IN}} = 1.8 + 0.01 \cdot \cos(\omega t)$$

$$v_{\text{OUT}}(v_{\text{IN}}) = 5 - 25 \cdot ((1.8 - 1.6) + 0.01 \cdot \cos(\omega t))^2$$

$$v_{\text{OUT}}(v_{\text{IN}}) = 5 - 25 \cdot ((0.2)^2 - 2 \cdot 0.2 \cdot 0.01 \cdot \cos(\omega t) - 0.01^2 \cdot \cos^2(\omega t))$$

$$v_{\text{OUT}}(v_{\text{IN}}) = 4 - 0.100 \cdot \cos(\omega t) - 0.0025 \cdot \cos^2(\omega t)$$

The first term is a DC offset, the second term is our fundamental with a gain of -10 (V/V), and the third is a harmonic due to the “x<sup>2</sup>” property of saturation mode.

If the cosine amplitude is sufficiently small, then the harmonic can be ignored.

**In general, we can find the fundamental gain (gain of the time varying signal) by taking the derivative of the transfer function and evaluating it at the DC bias.**

$$v_{OUT}(v_{IN}) = V_{DD} - 0.5 \cdot R_D \cdot k_n \cdot (v_{IN} - V_{tn})^2$$

$$v_{OUT}'(v_{IN}) = -R_D \cdot k_n \cdot (v_{IN} - V_{tn})$$

$$\text{Gain} = v_{OUT}'(v_{IN}=V_{IN\_DC}) = -R_D \cdot k_n \cdot (V_{IN\_DC} - V_{tn})$$

**for the previous values**

$$v_{IN} = 1.8 + 0.01 \cdot \cos(\omega t)$$

$$\text{Gain} = -2000 \cdot 0.025 \cdot 0.2 = -10 \text{ (V/V)}$$

**If the DC input is changed, so does the gain.**

$$v_{IN} = 1.7 + 0.01 \cdot \cos(\omega t)$$

$$\text{Gain} = -2000 \cdot 0.025 \cdot 0.1 = -5 \text{ (V/V)}$$

**Interestingly...we would get the same gain if  $V_{DD}=8$  V. why?**

This circuit is fine for the process to evaluate the gain of this circuit in saturation.

The x-fer  $v_{OUT}(v_{IN})$  was simple.

$$v_{OUT}(v_{IN}) = V_{DD} - 0.5 \cdot R_D \cdot k_n \cdot (v_{IN} - V_{tn})^2$$

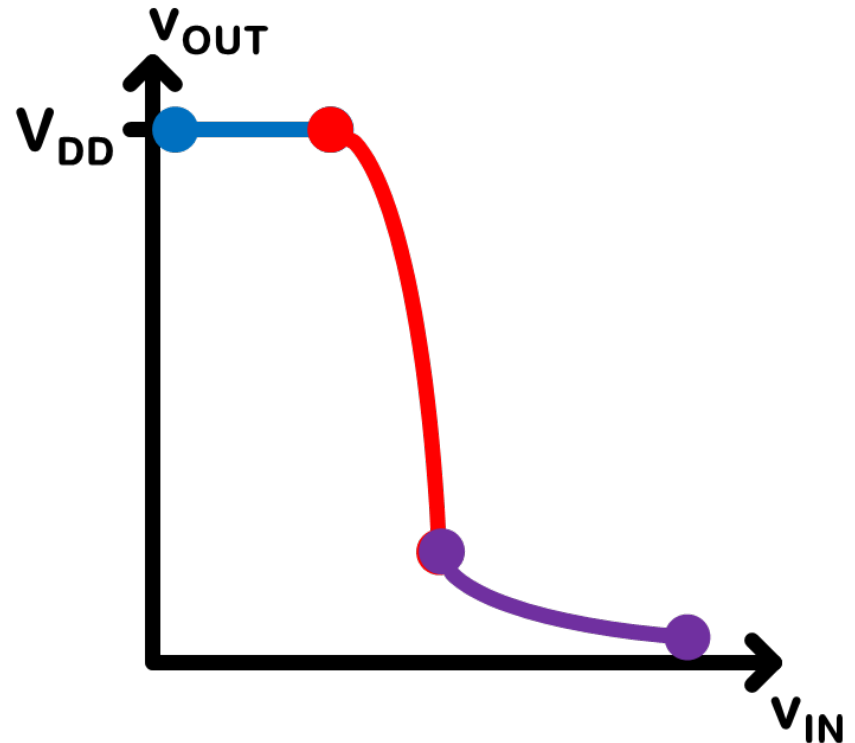
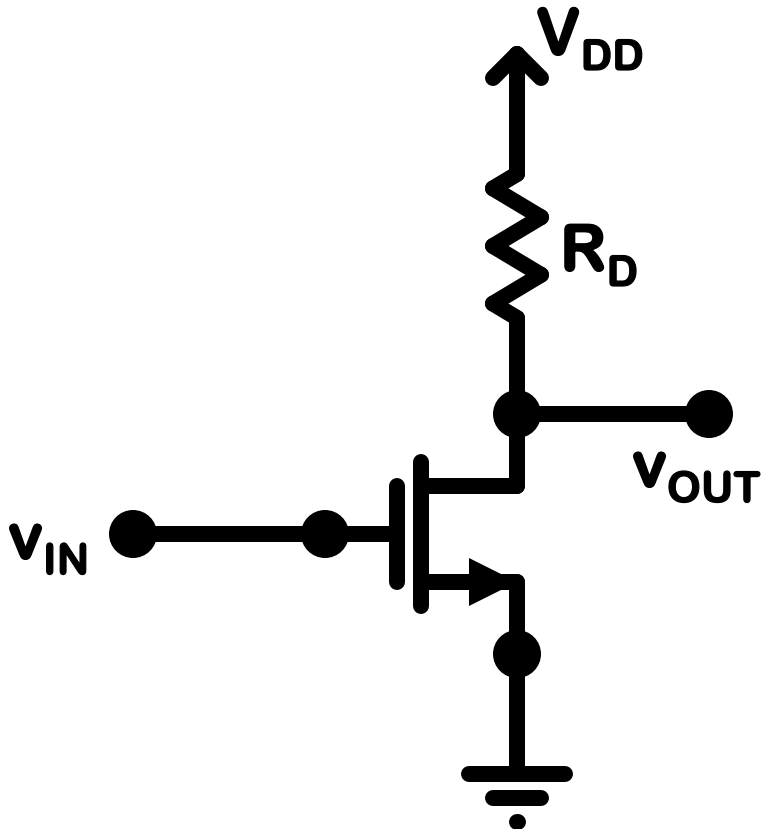

**Actual circuits are more complicated.**

**A simpler model of the MOSFET in saturation is needed for evaluating the small variations of an input.**

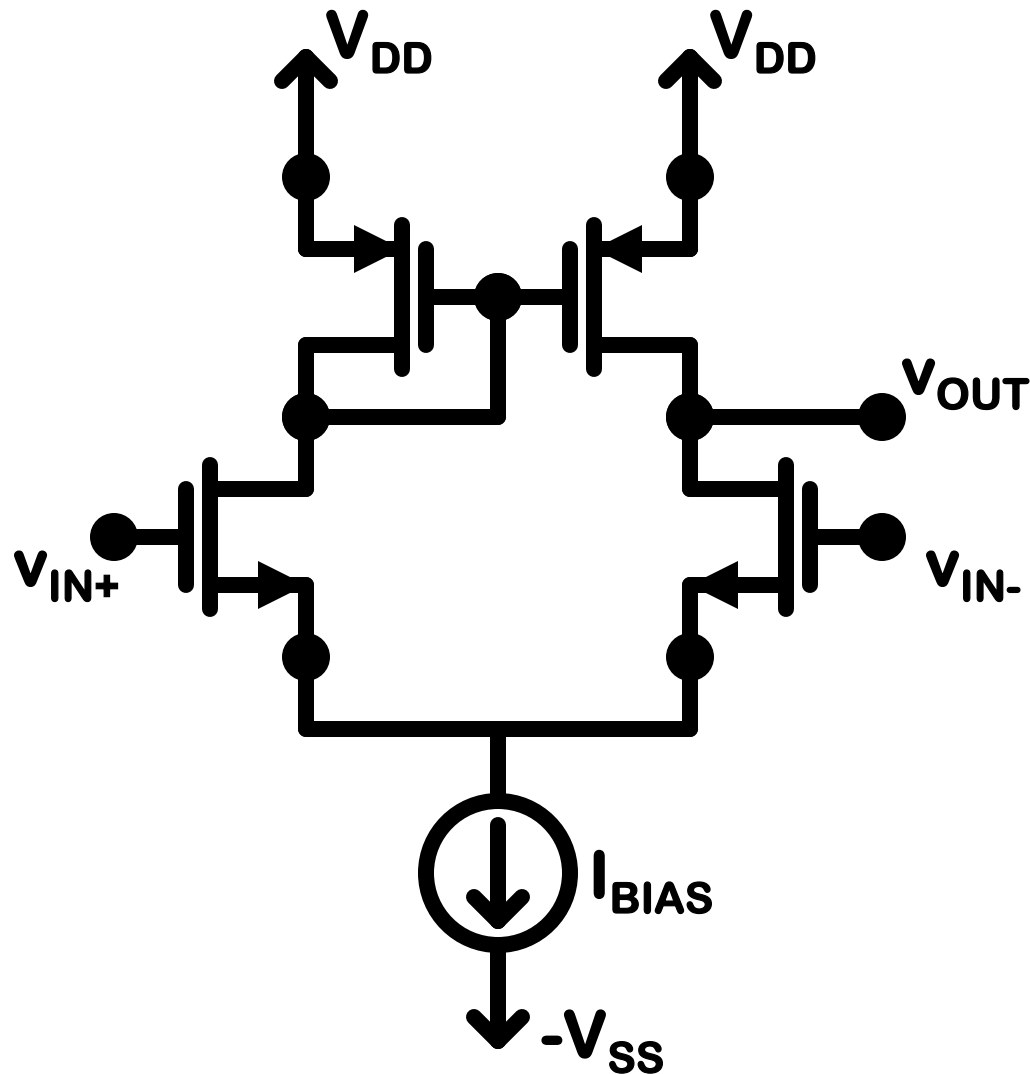

# MOSFET SMALL SIGNAL MODEL

## MOSFET Saturation equation

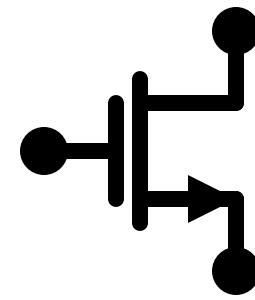

$$i_D(v_{GS}) = 0.5 \cdot k_n \cdot (v_{GS} - V_{tn})^2$$

**As we did with the diode, we would like to be able to use superposition to evaluate large signal “bias” voltages separately from the small signal “time varying” sources.**

**The device is non-linear so we need to use an approximation.**

**The approach.**

- 1. Use  $v_{GS}$  that has both a large ( $V_{GS}$ ) and small ( $v_{gs}$ ) component.**
- 2. Expand the equation (cross multiplying or series expansion).**
- 3. Identify the large signal, small signal, and error components.**
- 4. Interpret the components in terms of type of device.**

1.  $v_{GS} = V_{GS} + v_{gs}$

$$i_D(v_{GS}) = i_D(V_{GS} + v_{gs}) = 0.5 \cdot k_n \cdot (V_{GS} + v_{gs} - V_{tn})^2$$

## 2. Expand

$$i_D(V_{GS} + v_{gs}) = 0.5 \cdot k_n \cdot ((V_{GS} - V_{tn})^2 + 2 \cdot (V_{GS} - V_{tn}) \cdot v_{gs} + v_{gs}^2)$$
$$i_D = 0.5 \cdot k_n \cdot (V_{GS} - V_{tn})^2 + k_n \cdot (V_{GS} - V_{tn}) \cdot v_{gs} + 0.5 \cdot k_n \cdot v_{gs}^2$$

3.  $i_D = I_D + i_d$

Large Signal:  $I_D = 0.5 \cdot k_n \cdot (V_{GS} - V_{tn})^2$

Small Signal:  $i_d = k_n \cdot (V_{GS} - V_{tn}) \cdot v_{gs}$

Error Term:  $i_{ERR} = 0.5 \cdot k_n \cdot v_{gs}^2$

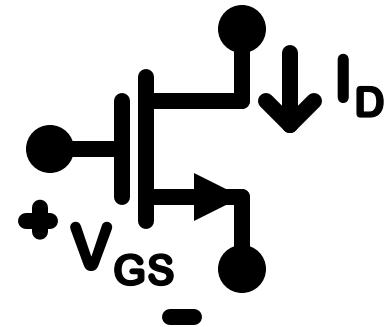

## 4. Interpretation

$I_D = 0.5 \cdot k_n \cdot (V_{GS} - V_{tn})^2$  is a MOSFET in Saturation.

$i_d = k_n \cdot (V_{GS} - V_{tn}) \cdot v_{gs}$  is a trans-conductance.

$i_d = g_m \cdot v_{gs}$  where  $g_m = k_n \cdot (V_{GS} - V_{tn})$

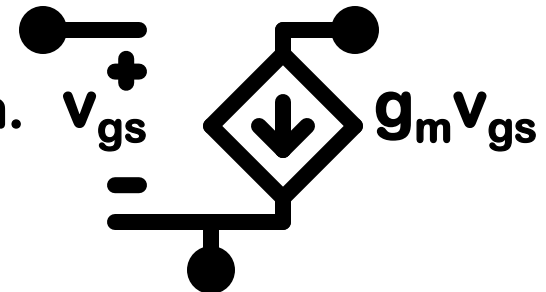

# Small Signal Analysis with Common Source Circuit

$V_{DD} = 5\text{ V}$   
 $R_D = 2000\ \Omega$   
 $k_n = 25\text{ mA/V}^2$   
 $V_{tn} = 1.6\text{ V}$

$V_{IN} = 1.8 + 0.01 \cdot \cos(\omega t)$

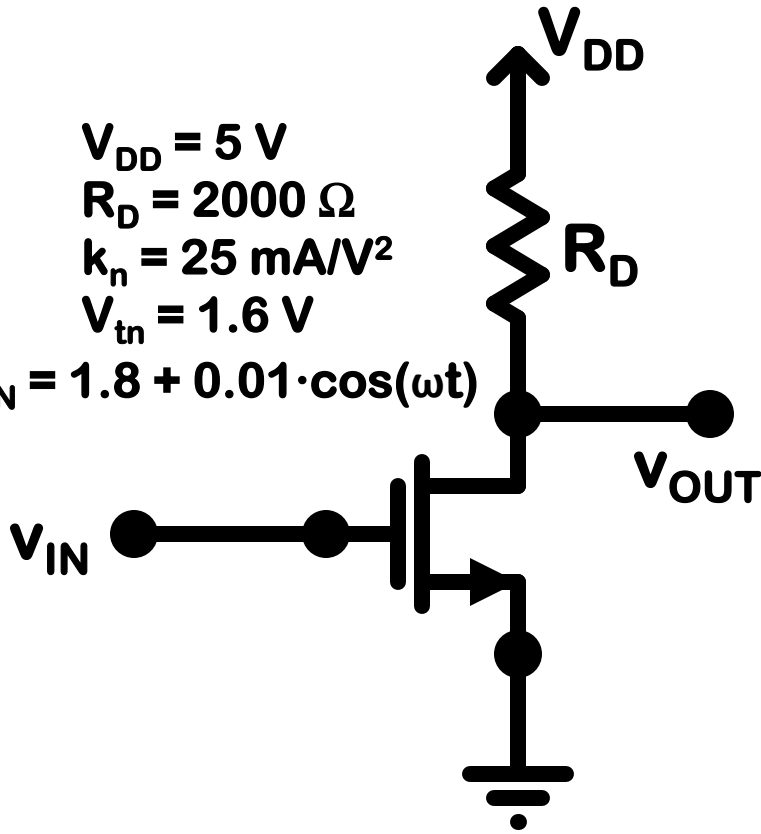

**Large  
Signal  
Circuit**

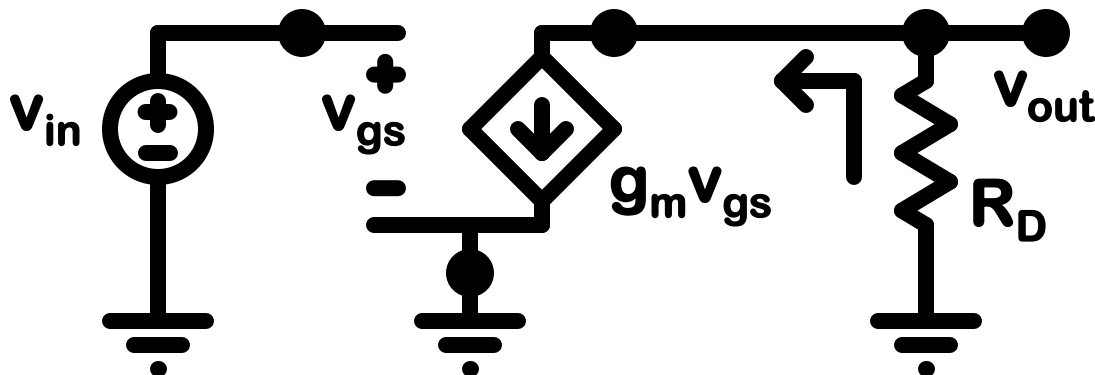
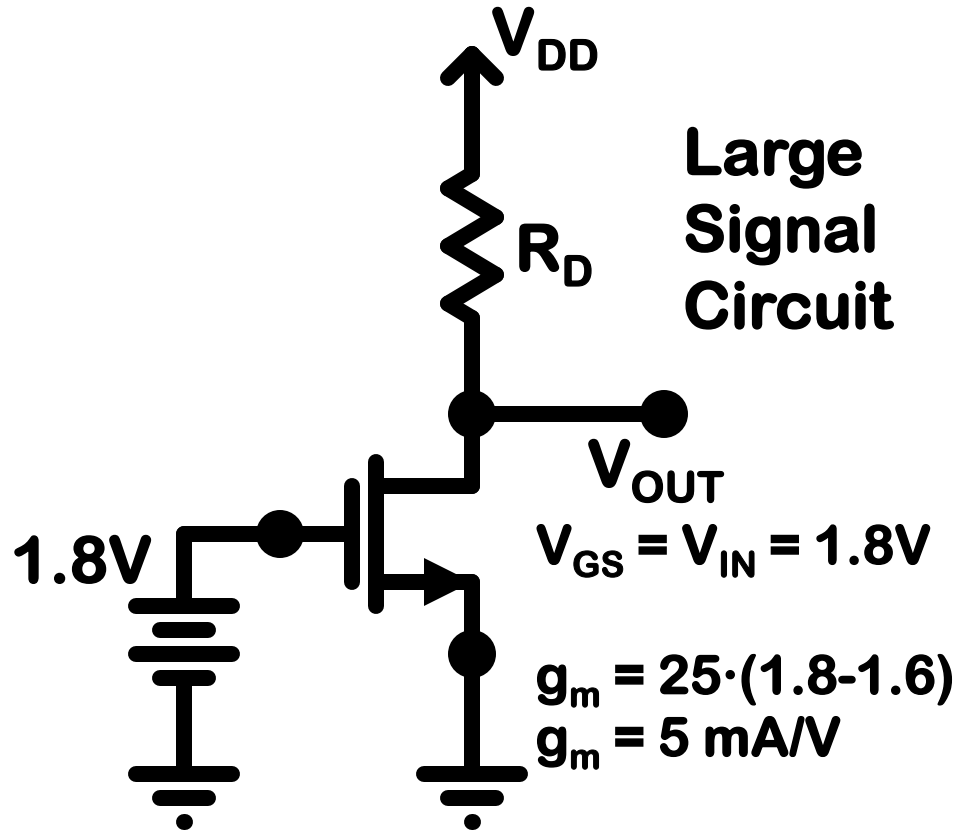

**Small Signal Circuit**

$v_{gs} = v_{in} = 0.01 \cdot \cos(\omega t)$   
 $v_{out} = -0.005 \cdot 2000 \cdot v_{gs}$   
 $v_{out} = -0.1 \cdot \cos(\omega t)$   
**Gain = -10 (V/V)**

# Another Example with Large Capacitors and Inductor

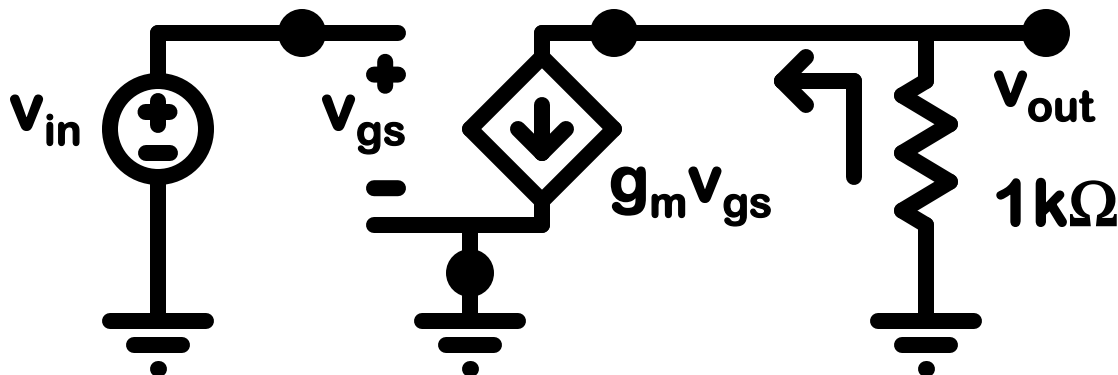
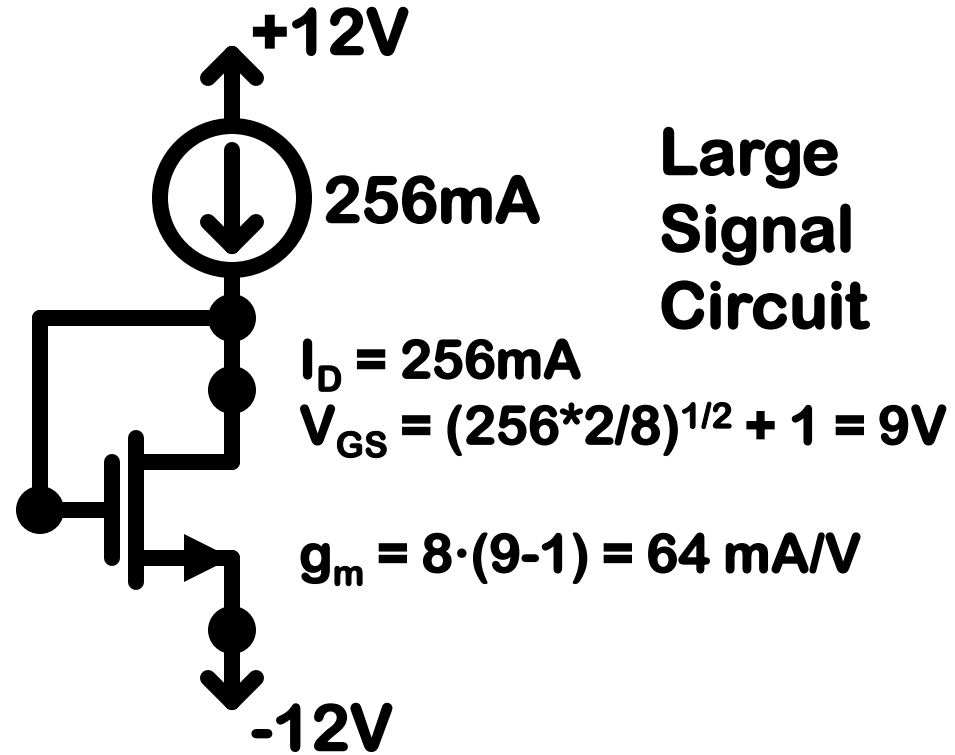
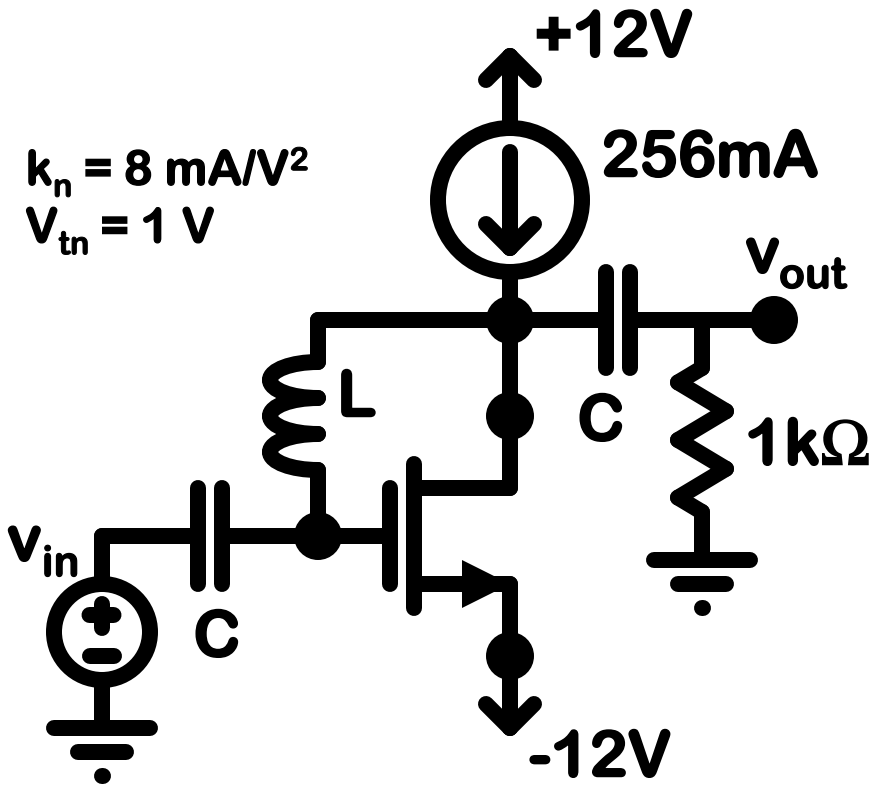

## Small Signal Circuit

$$v_{gs} = v_{in}$$

$$v_{out} = -.064 \cdot 1000 \cdot v_{gs}$$

$$v_{out}/v_{in} = -64 \text{ (V/V)}$$

# MORE REALISTIC SMALL SIGNAL MODEL

Relationship to  $v_{DS}$  is linear.

$$i_D(v_{GS}, v_{DS}) = 0.5 \cdot k_n \cdot (V_{GS} + v_{gs} - V_{tn})^2 \cdot (1 + \lambda v_{DS})$$

The value of  $\lambda$  is small enough that we typically only use it in the small signal circuit. Treat the relationship as a resistor.

Large Signal:  $I_D = 0.5 \cdot k_n \cdot (V_{GS} - V_{tn})^2$

Small Signal:  $i_d = g_m \cdot v_{gs} + v_{ds}/r_o$

$$g_m = k_n \cdot (V_{GS} - V_{tn}) \text{ and } r_o = (\lambda \cdot I_D)^{-1} = V_A / I_D$$

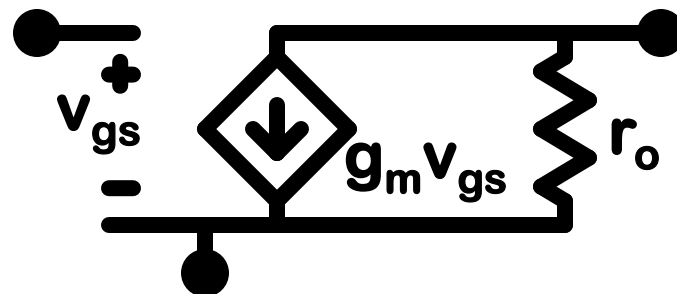
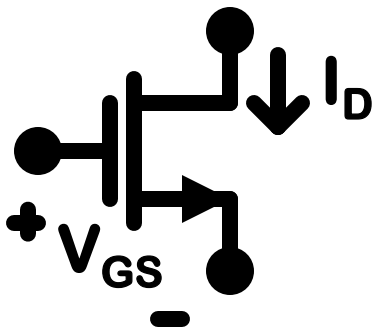

# Small Signal Analysis – rely on $r_o$ to provide voltage gain.

**Large  
Signal  
Circuit**

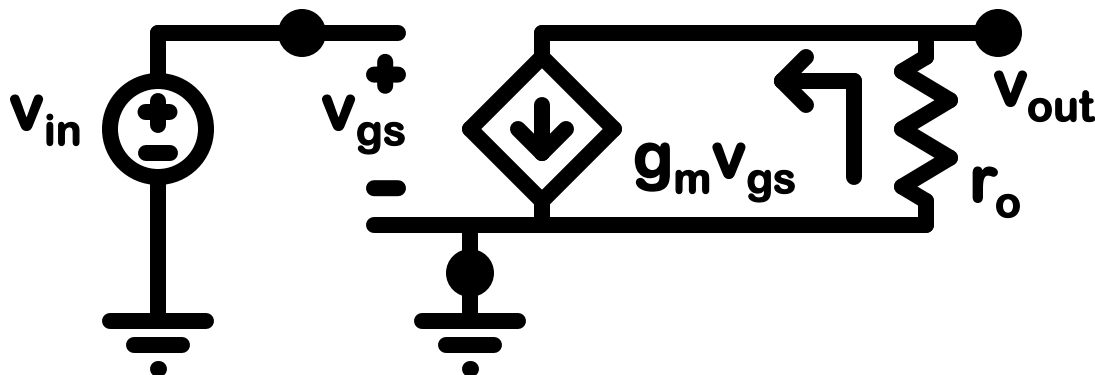
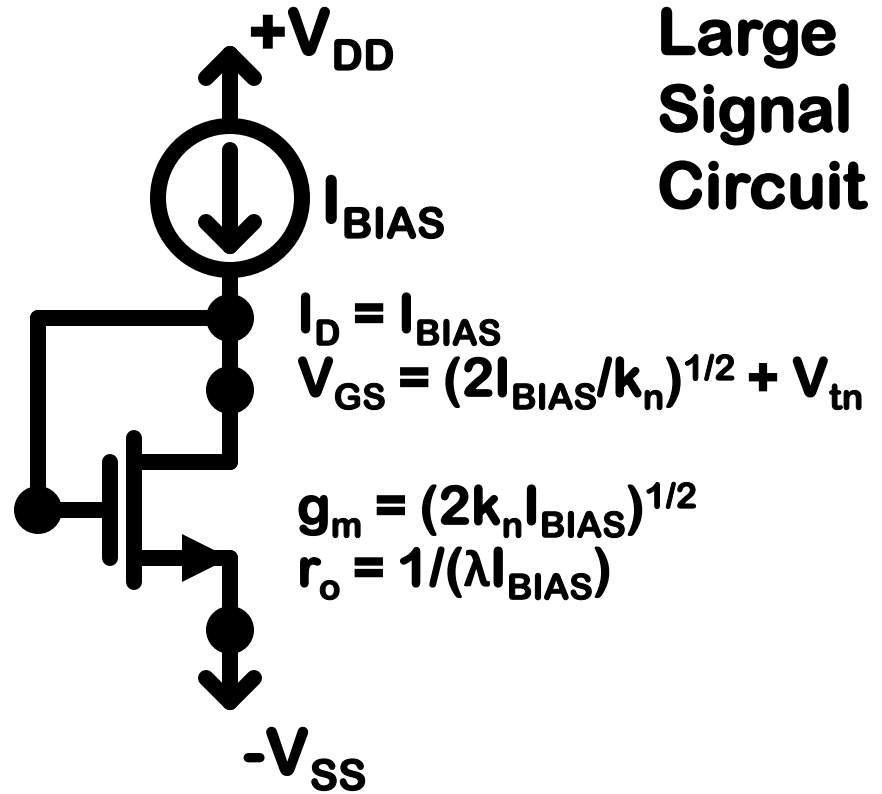
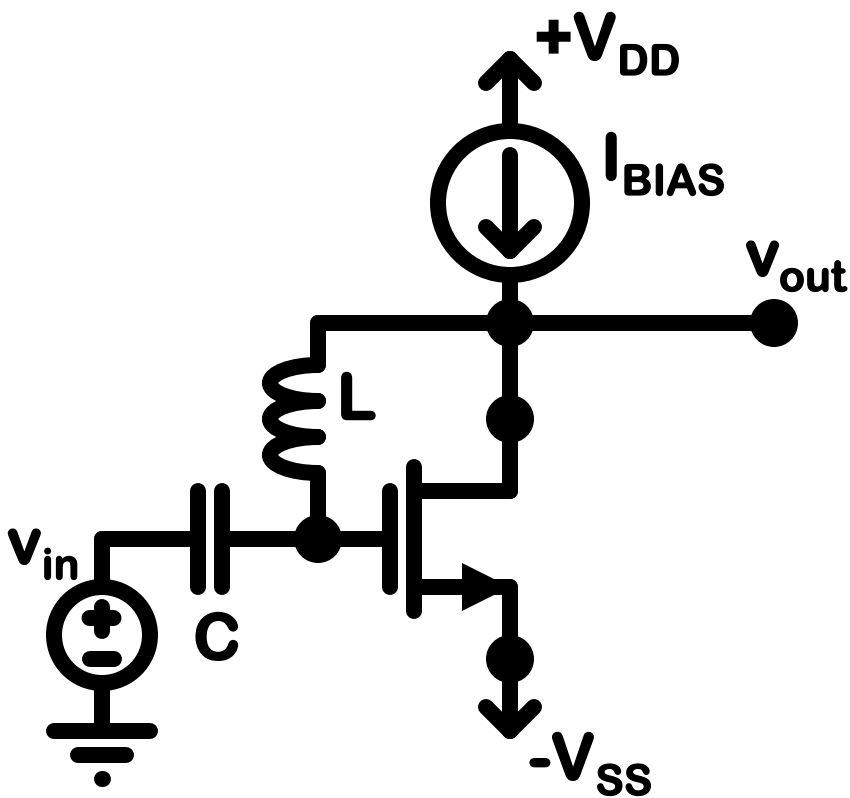

**Small Signal Circuit**

$$v_{out} = -g_m \cdot r_o \cdot v_{gs}$$

$$v_{out}/v_{in} = -(2k_n I_{BIAS})^{1/2} / (\lambda I_{BIAS})$$

$$v_{out}/v_{in} = -(2k_n / I_{BIAS})^{1/2} / \lambda$$

**Actual circuits are more complicated.**

**A simpler model of the MOSFET in saturation for evaluating the small variations of the input would be helpful.**

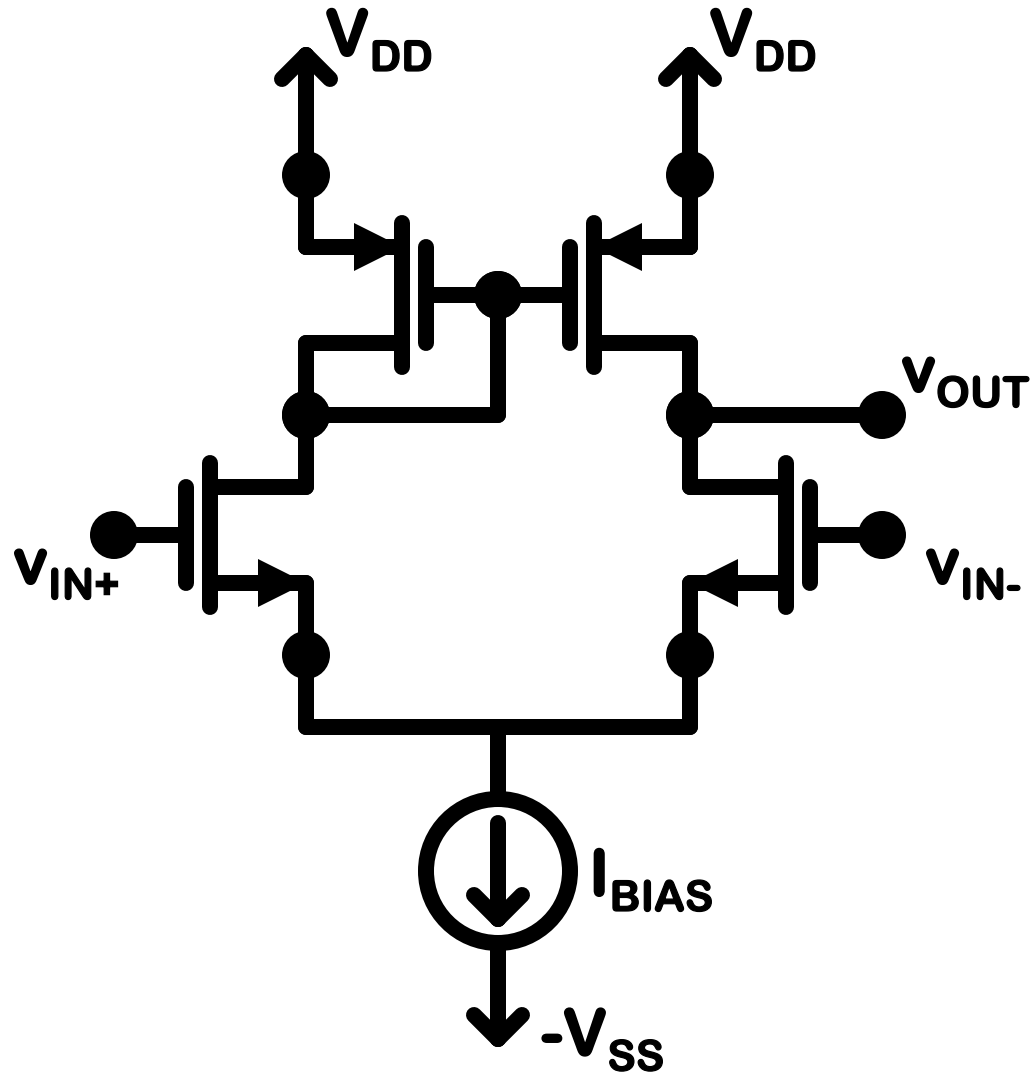

$I_D$  for all devices is  $I_{BIAS}/2$ .

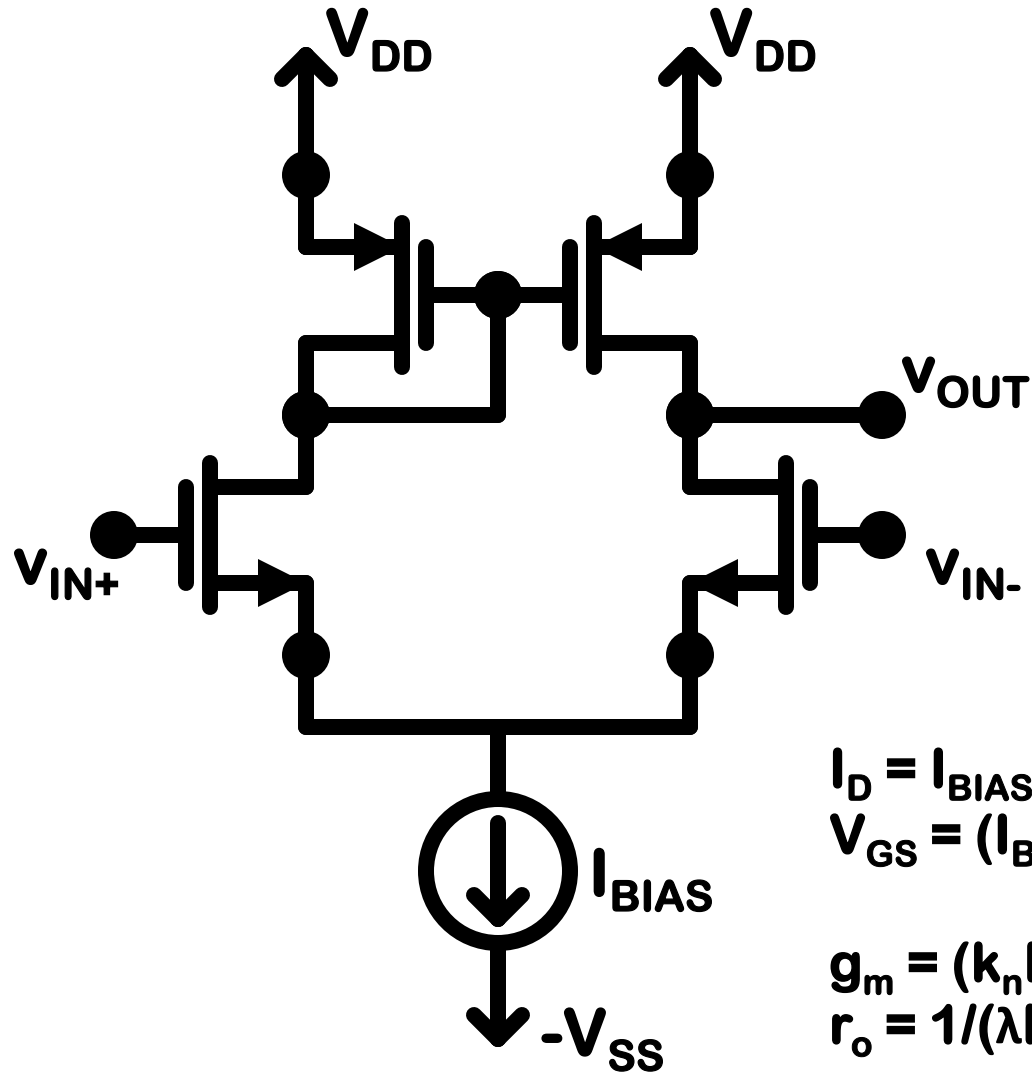

$$I_D = I_{BIAS}/2$$

$$V_{GS} = (I_{BIAS}/k_n)^{1/2} + V_{tn}$$

$$g_m = (k_n I_{BIAS})^{1/2}$$

$$r_o = 1/(\lambda I_{BIAS})$$

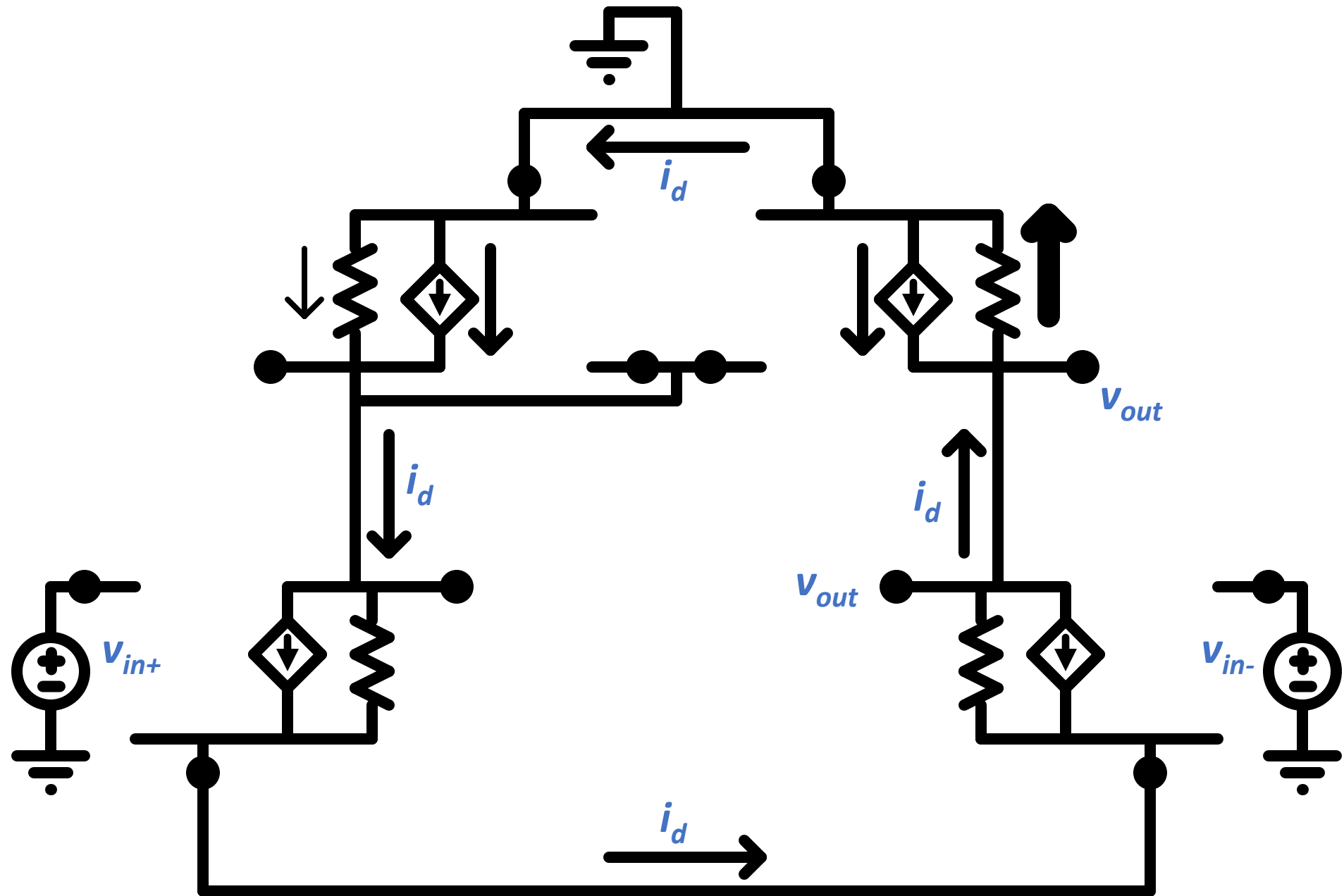

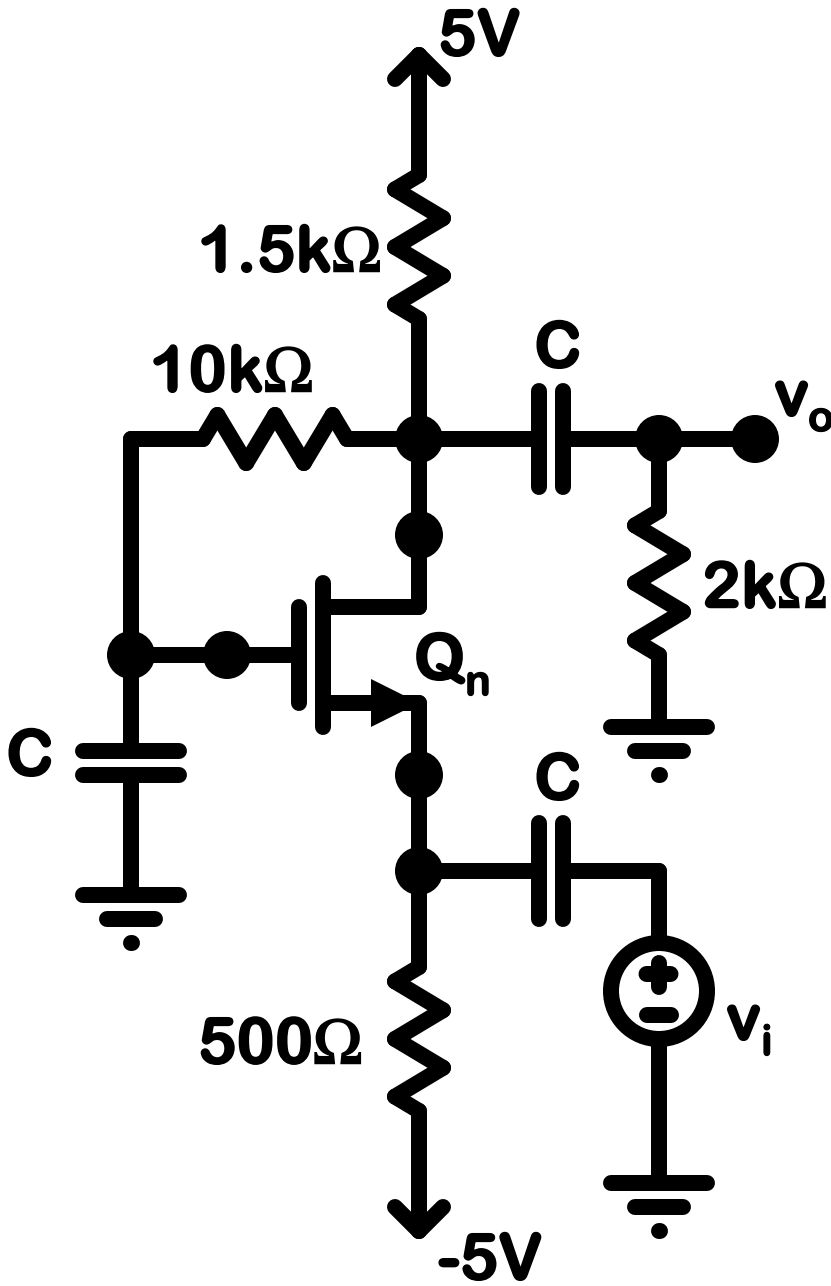

$Q_n$ :  
 $k_n = 5 \text{ mA/V}^2$   
 $V_{tn} = 2\text{V}$   
 $V_A = 50\text{V}$

$Q_n$ :  
 $k_n = 5 \text{ mA/V}^2$   
 $V_{tn} = 2\text{V}$   
 $V_A = 50\text{V}$

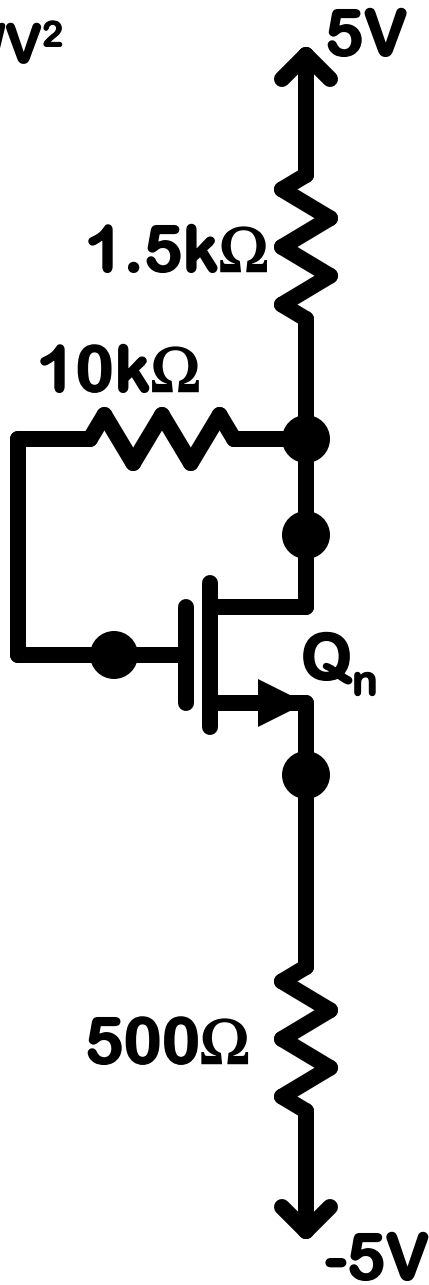

Enforce

$$I_D = 0.5 \cdot 0.005 \cdot (V_{GS} - V_{tn})^2$$

$$V_{GS} = V_{DS}$$

$$5 - I_D \cdot 1.5\text{k} - V_{DS} - I_D \cdot 0.5\text{k} = -5$$

$$I_D = (10 - V_{DS}) / 2\text{k}$$

$$0.0025 \cdot (V_{GS} - 2)^2 = (10 - V_{GS}) / 2000$$

$$5 \cdot V_{GS}^2 - 20 \cdot V_{GS} + 20 = 10 - V_{GS}$$

$$5 \cdot V_{GS}^2 - 19 \cdot V_{GS} - 10 = 0$$

$$V_{GS} = (19 + (19^2 + 4 \cdot 5 \cdot 10)^{1/2}) / (2 \cdot 5)$$

$$V_{GS} = 3.17\text{V}$$

$$I_D = 3.4\text{mA}$$

$$g_m = 5.8\text{mA/V}$$

$$r_o = 14.6\text{k}\Omega$$

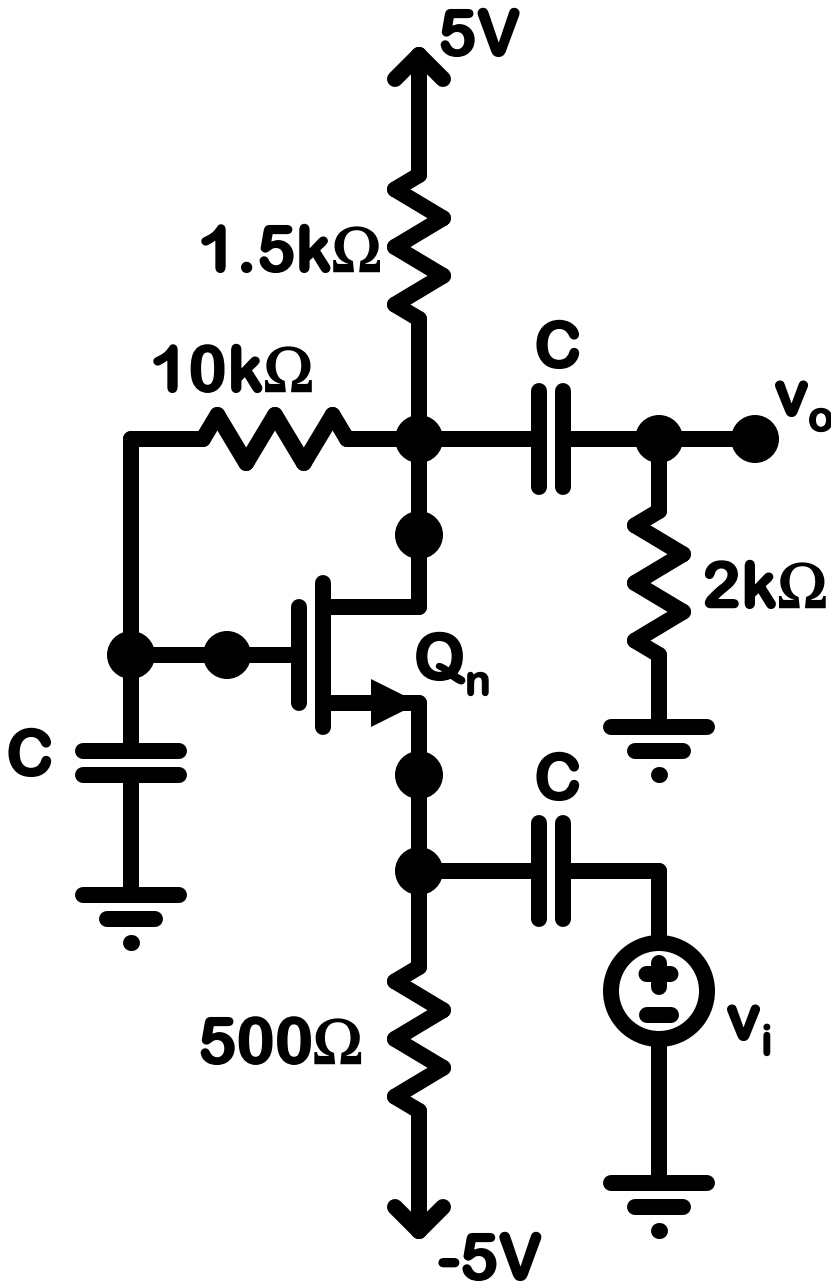

$Q_n$ :  
 $k_n = 5 \text{ mA/V}^2$   
 $V_{tn} = 2\text{V}$   
 $V_A = 50\text{V}$

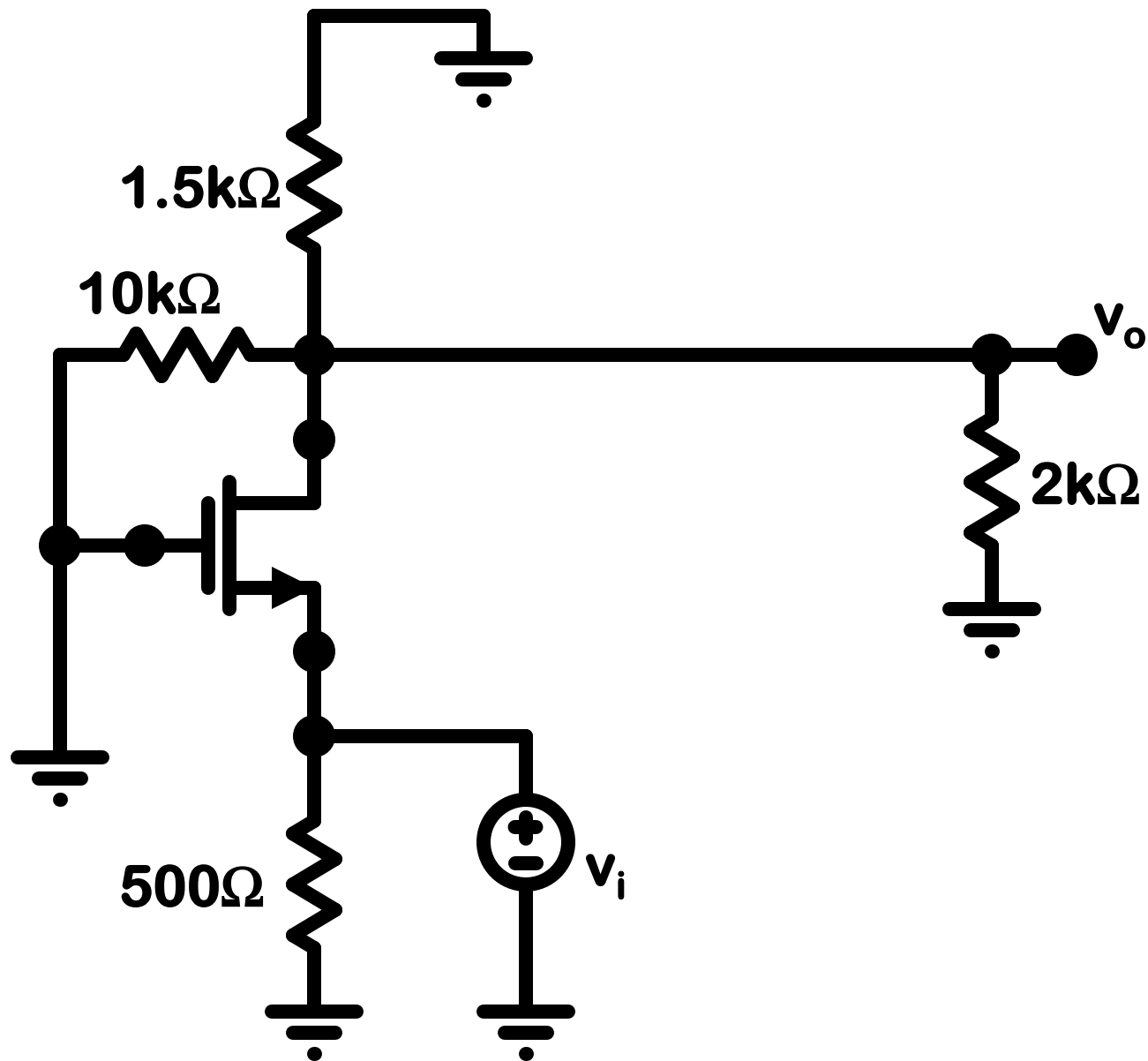

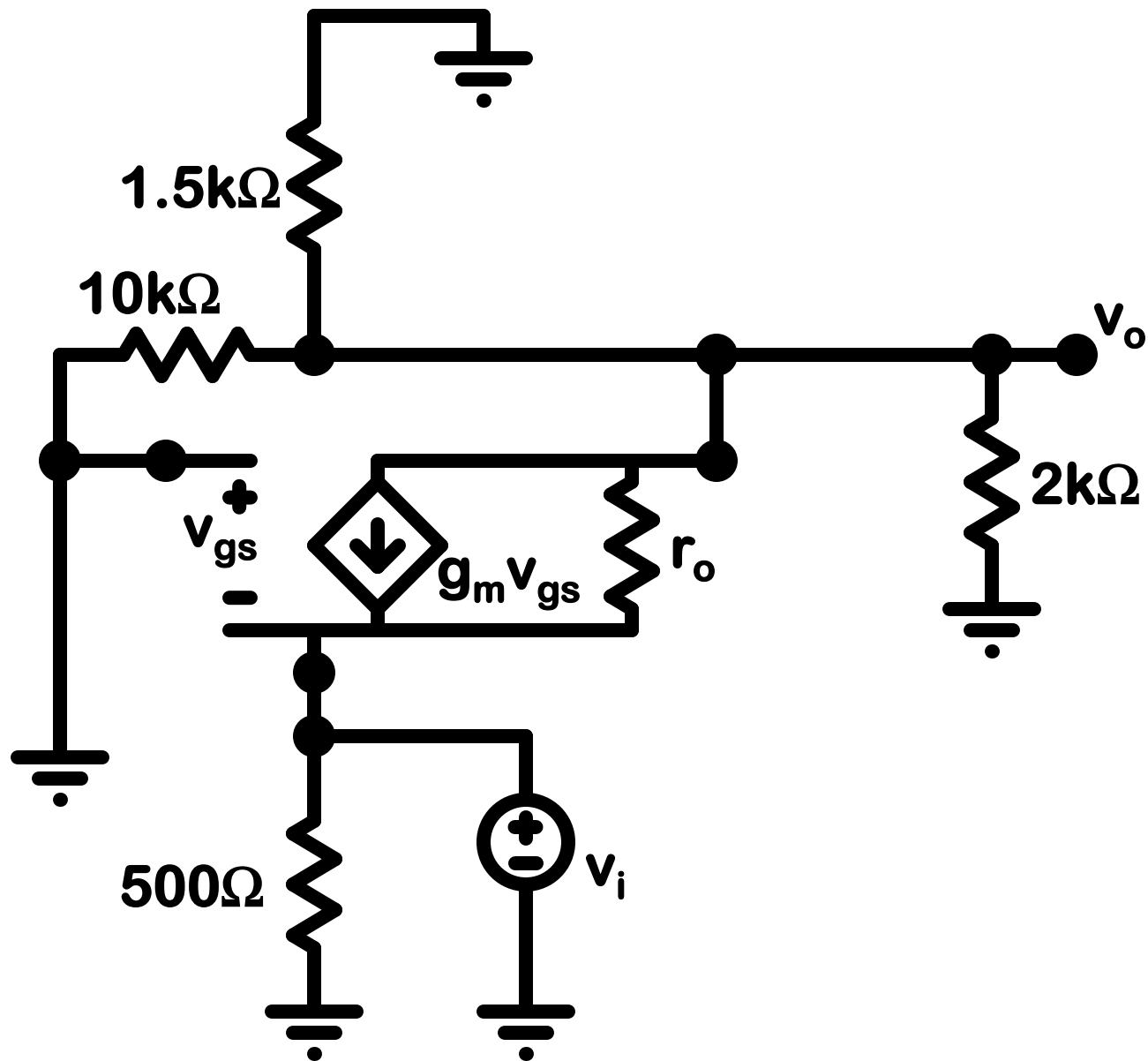

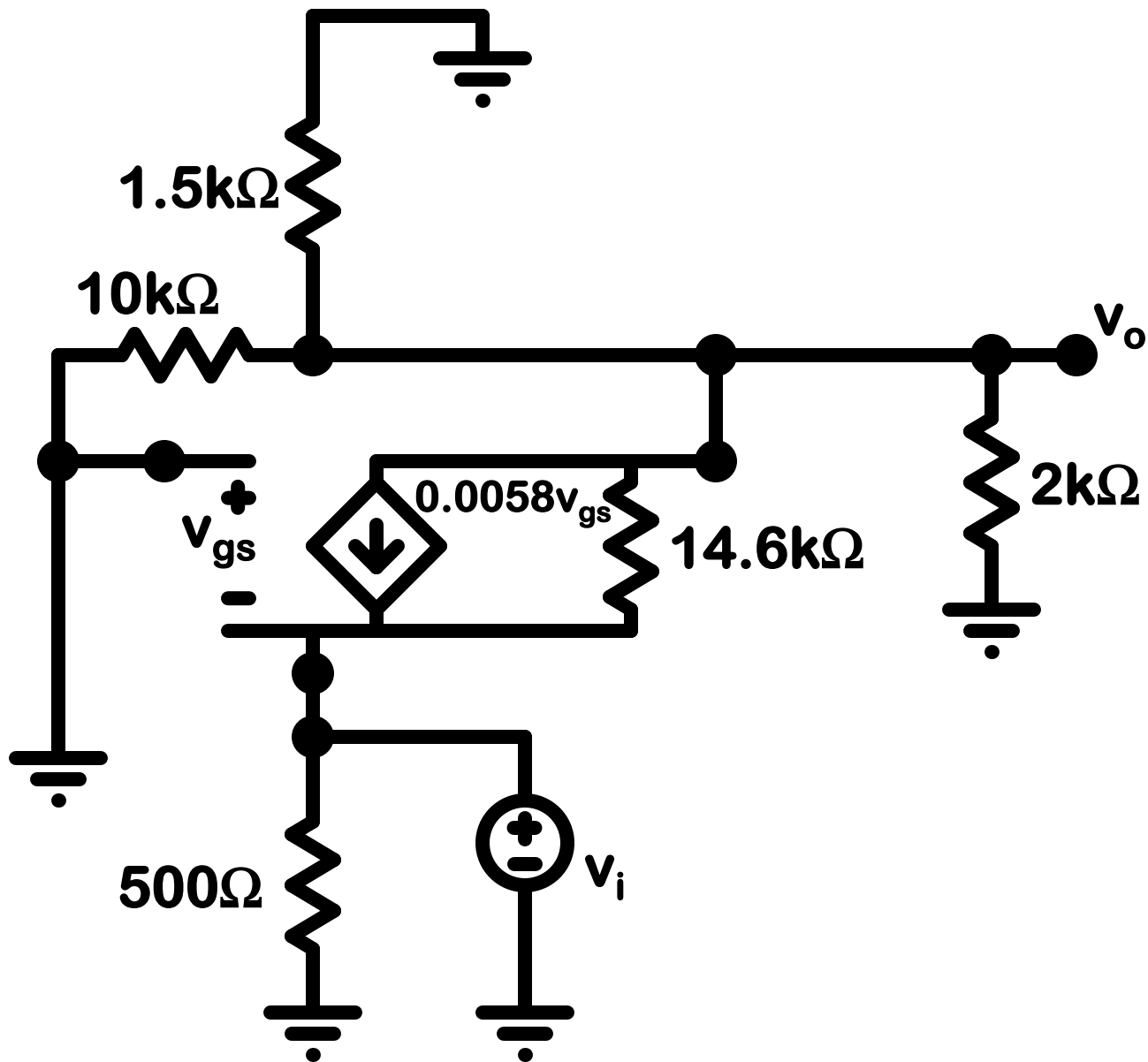

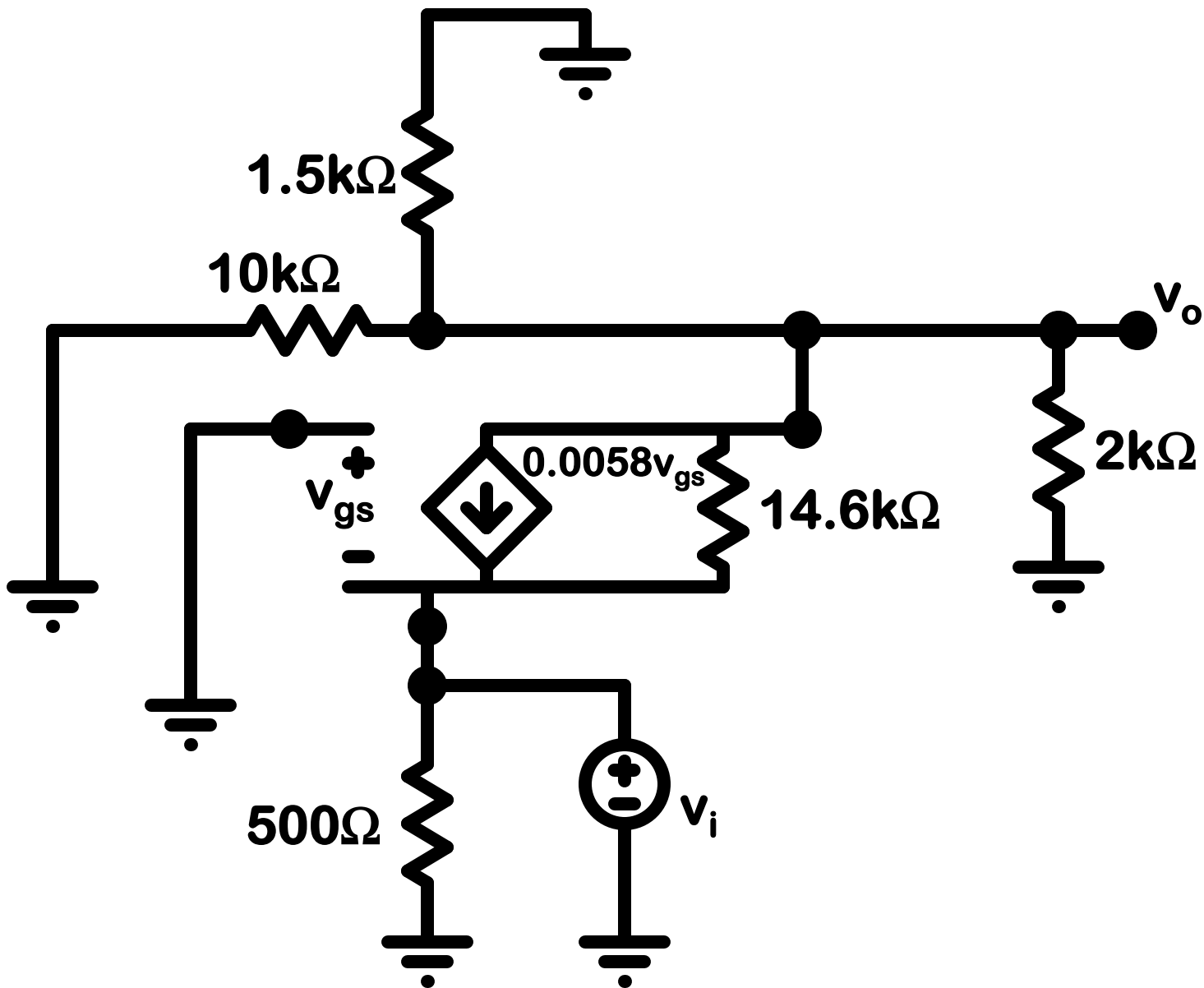

$$V_{gs} = V_g - V_s = -v_i$$

KCL at  $v_o$ :

$$v_o/790 + (v_o - v_i)/14.6k - 0.0058*v_i = 0$$

$$v_o(1/790 + 1/14.6) = v_i(1/14.6 + 0.0058)$$

$$v_o/v_i = 4.4 \text{ (V/V)}$$

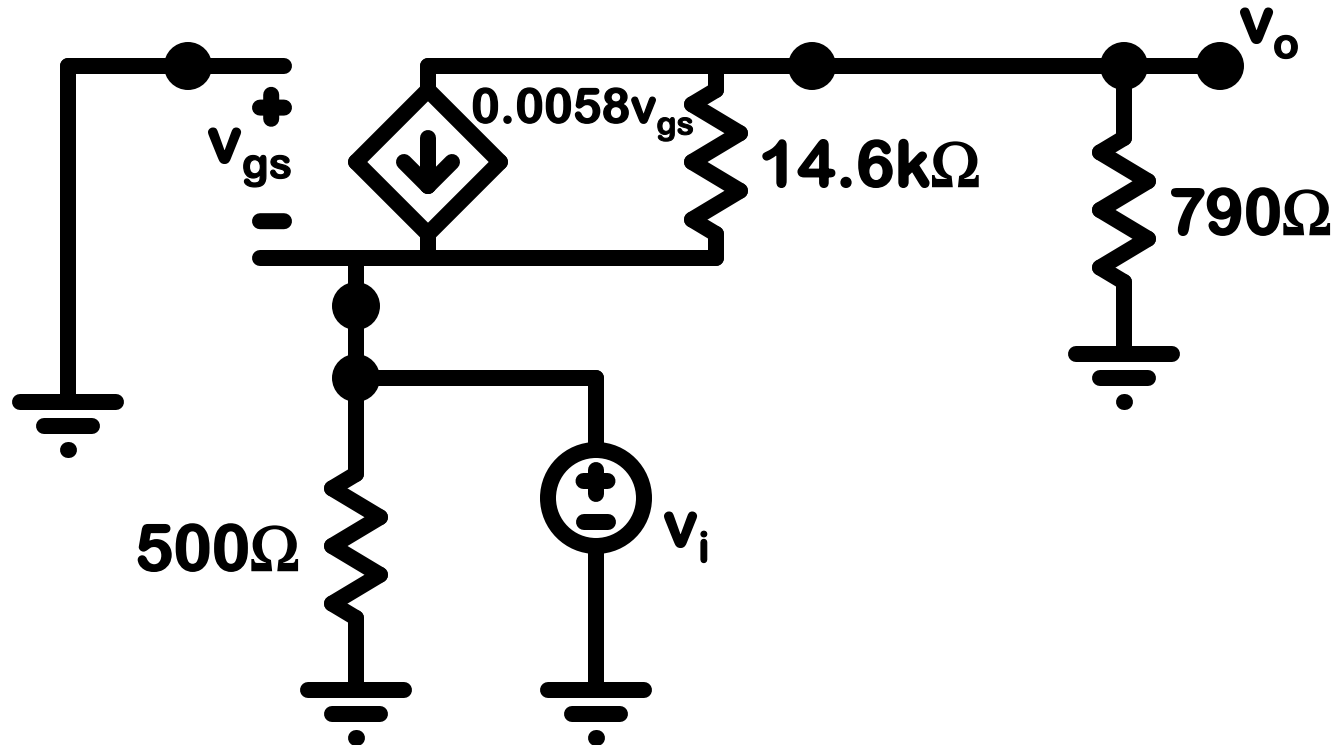

$Q_n$ :  
 $k_n = 2\text{mA/V}^2$   
 $V_{tn} = 1\text{V}$   
 $V_A = 40\text{V}$

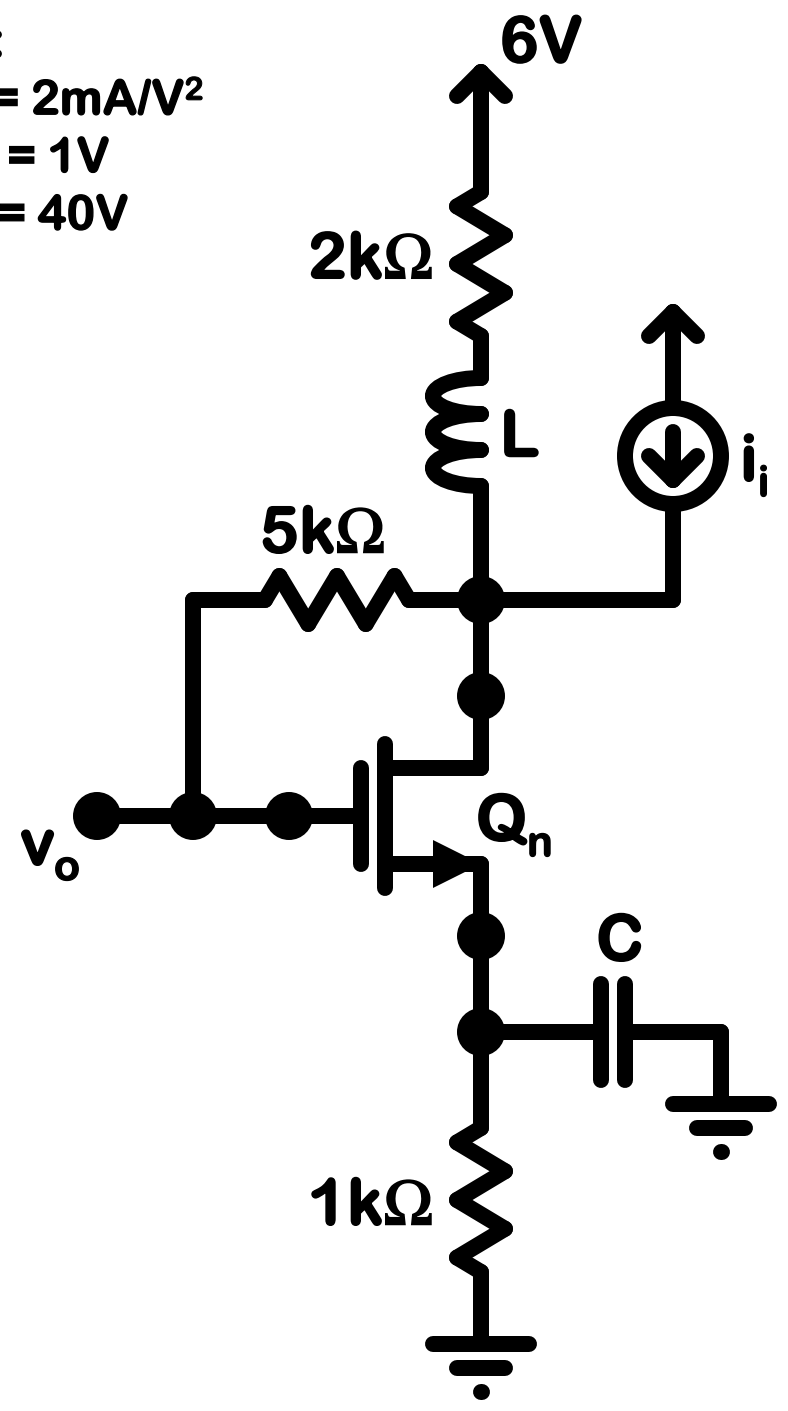

$Q_n$ :  
 $k_n = 2\text{mA/V}^2$   
 $V_{tn} = 1\text{V}$   
 $V_A = 40\text{V}$

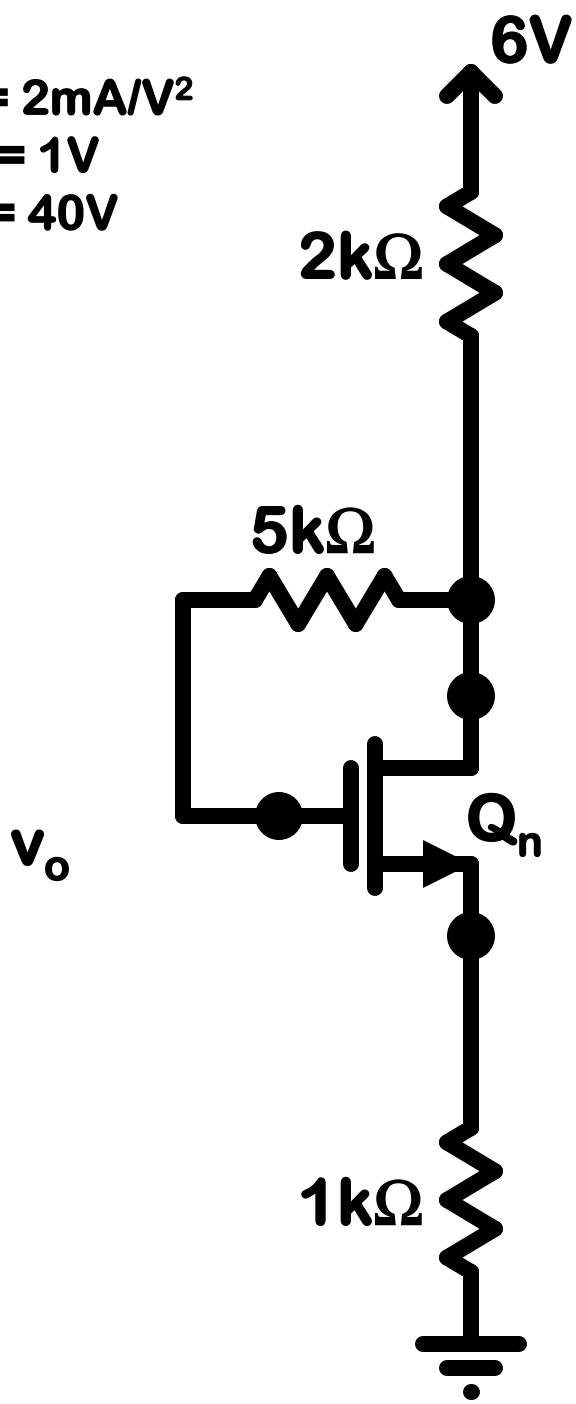

**Enforce**

$$I_D = 0.5 * 0.002 * (V_{GS} - V_{tn})^2$$

$$V_{GS} = V_{DS}$$

$$6 - I_D * 2\text{k} - V_{DS} - I_D * 1\text{k} = 0$$

$$I_D = (6 - V_{DS}) / 3\text{k}$$

$$0.001 * (V_{GS} - 1)^2 = (6 - V_{GS}) / 3000$$

$$3 * V_{GS}^2 - 6 * V_{GS} + 3 = 6 - V_{GS}$$

$$3 * V_{GS}^2 - 5 * V_{GS} - 3 = 0$$

$$V_{GS} = (5 + (5^2 + 4 * 3 * 3)^{1/2}) / (2 * 3)$$

$$V_{GS} = 2.135\text{V}$$

$$I_D = 1.3\text{mA}$$

$$g_m = 2.3\text{mA/V}$$

$$r_o = 31\text{k}\Omega$$

$Q_n$ :  
 $k_n = 2\text{mA/V}^2$   
 $V_{tn} = 1\text{V}$   
 $V_A = 40\text{V}$

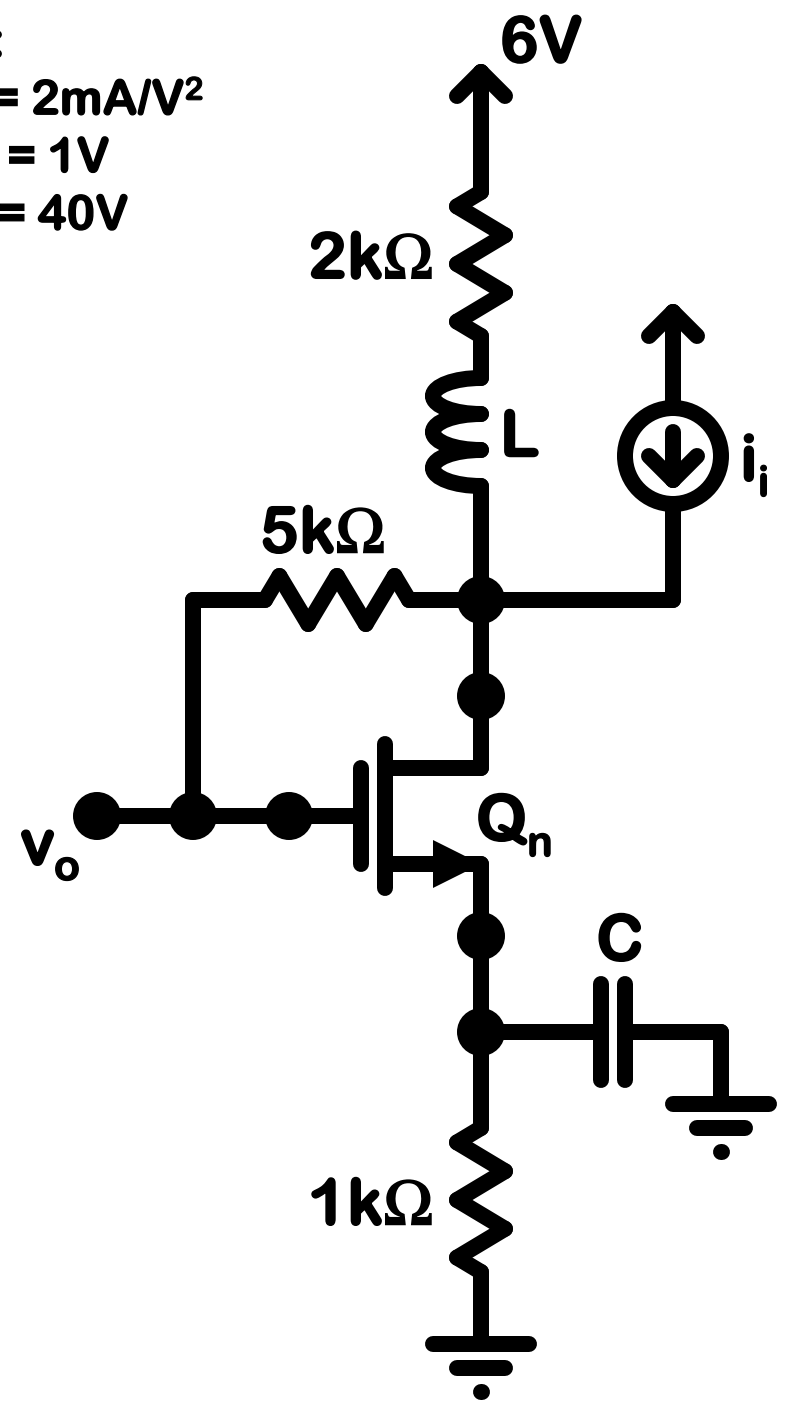

$Q_n$ :  
 $k_n = 2\text{mA/V}^2$   
 $V_{tn} = 1\text{V}$   
 $V_A = 40\text{V}$

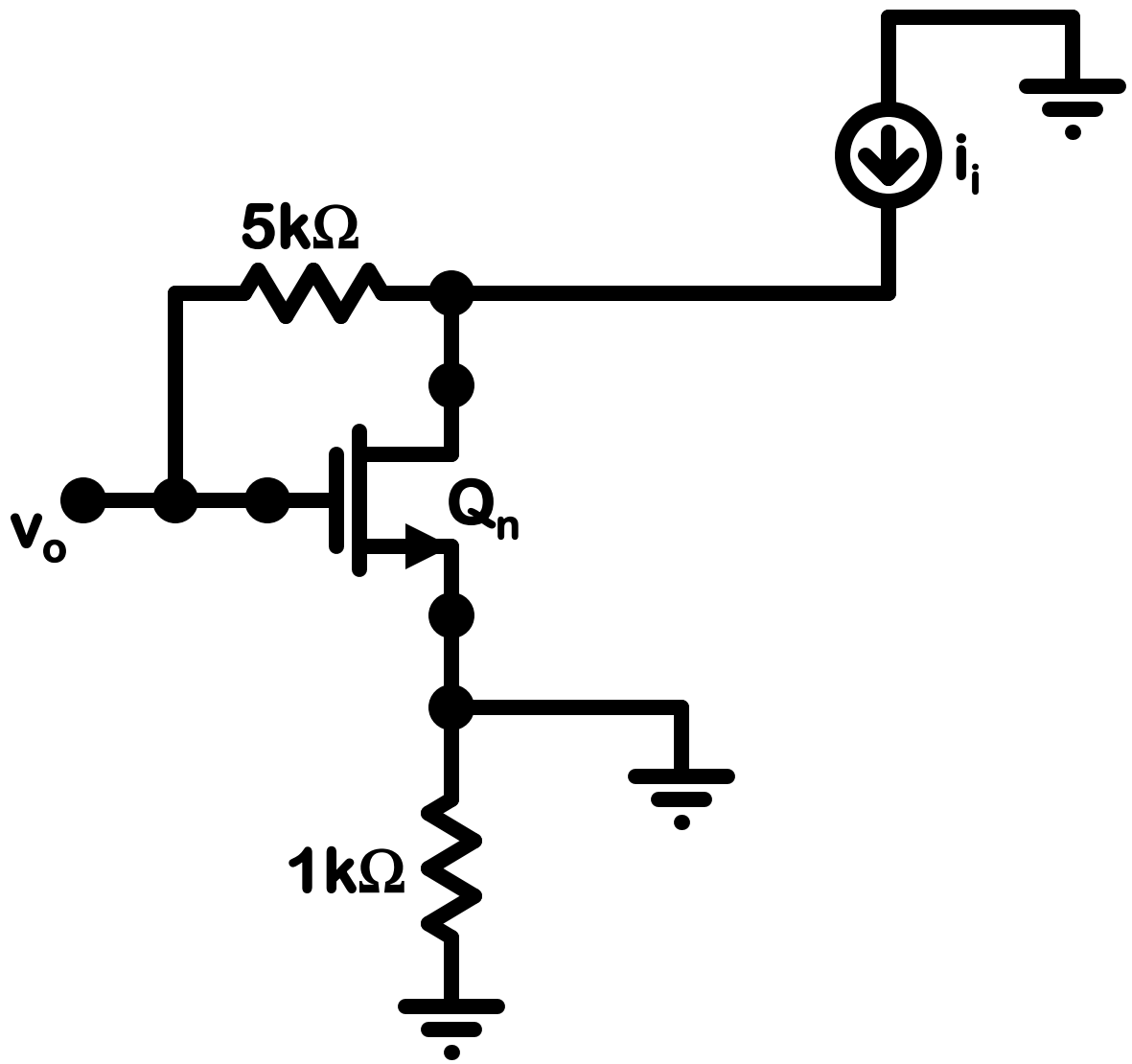

$Q_n$ :  
 $k_n = 2\text{mA/V}^2$   
 $V_{tn} = 1\text{V}$   
 $V_A = 40\text{V}$

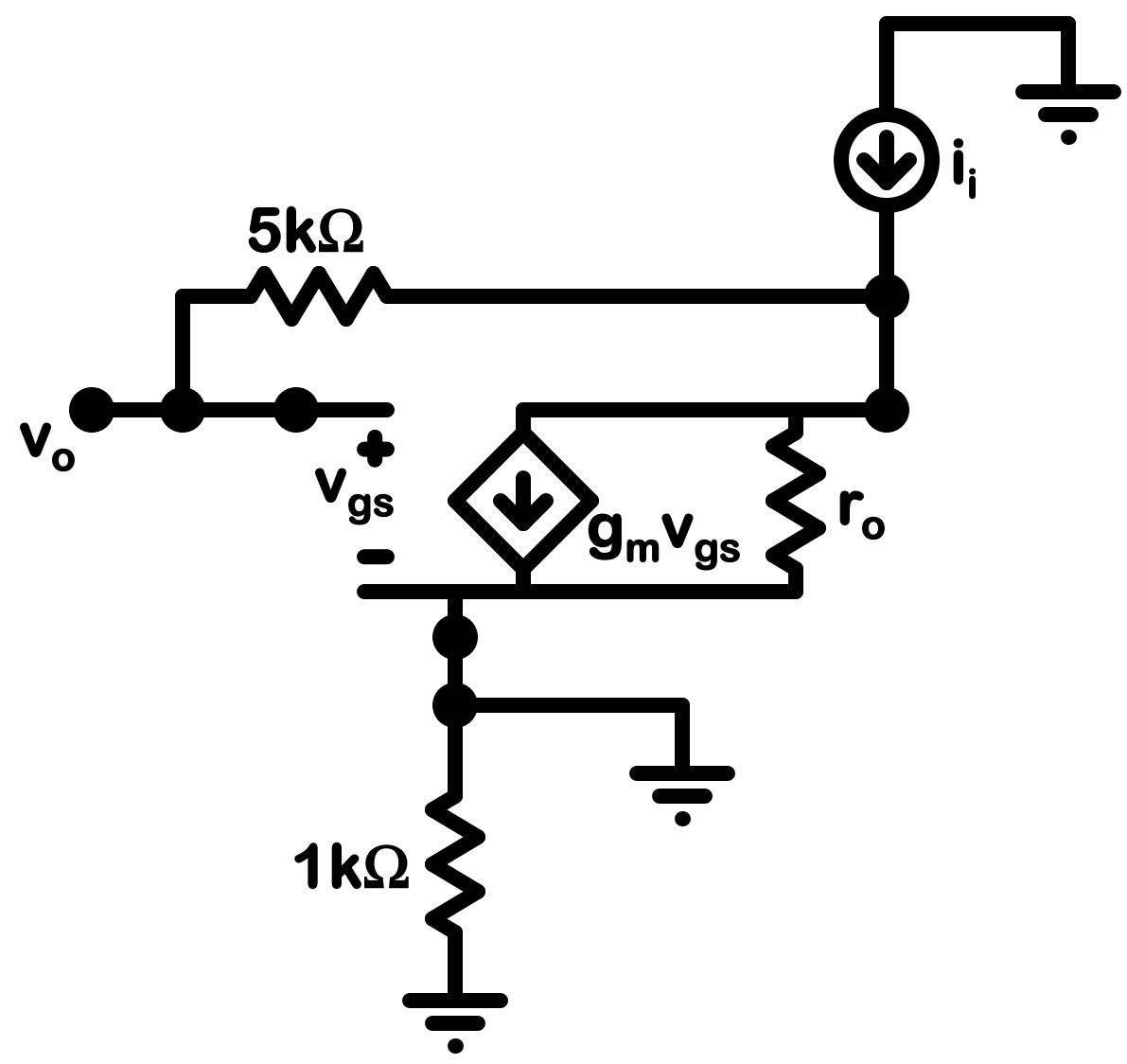

$Q_n$ :  
 $k_n = 2\text{mA/V}^2$   
 $V_{tn} = 1\text{V}$   
 $V_A = 40\text{V}$

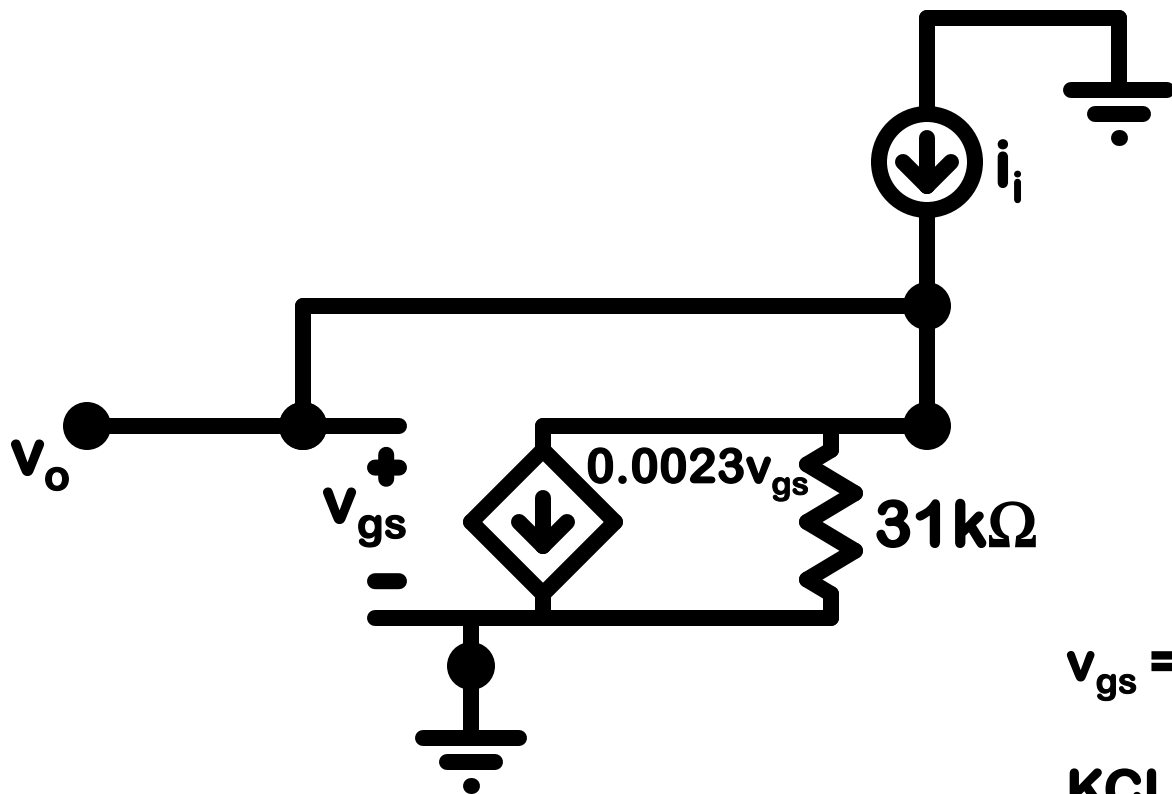

$$v_{gs} = v_o$$

KCL at  $v_o$ :

$$i_i = v_o/31\text{k} + 0.0023*v_o$$

$$v_o(1/31 + 2.3) = 1000i_i$$

$$v_o/i_i = 430\Omega$$