

Review

- What we have covered.
 - Circuits Devices Review
 - Characterizing a device i-v equation & plot.
 - Solving circuits and transfer functions.
 - The Ideal Diode
 - A new “non-linear” device.
 - Characteristics, i-v eq. & plot, models (short or open).
 - Solving circuits and transfer functions.

Forward

- What we will cover.
 - Application of diodes.
 - Simple digital logic (and-gates, or-gates).
 - The Junction Diode.
 - Characteristics, i-v equation and plots.
 - Solving circuits.
 - Modeling the Junction Diode.
 - Applications: Voltage Regulator.

The Junction Diode

Junction Diodes:

- An implementation of a diode using semiconductor tech.

A) The Junction Diode Symbol

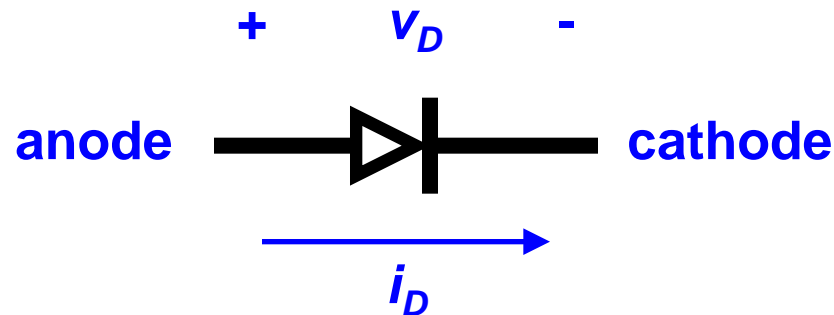

- Similar to the ideal diode.

Why is it called the junction diode?

- It is made by joining two different materials.

How is the Junction Diode different than the Ideal Diode?

- Look at the i-v characteristic.
- Relate to our mechanical valve.

The Junction Diode

- A real valve will not open unless there is a certain amount of pressure.

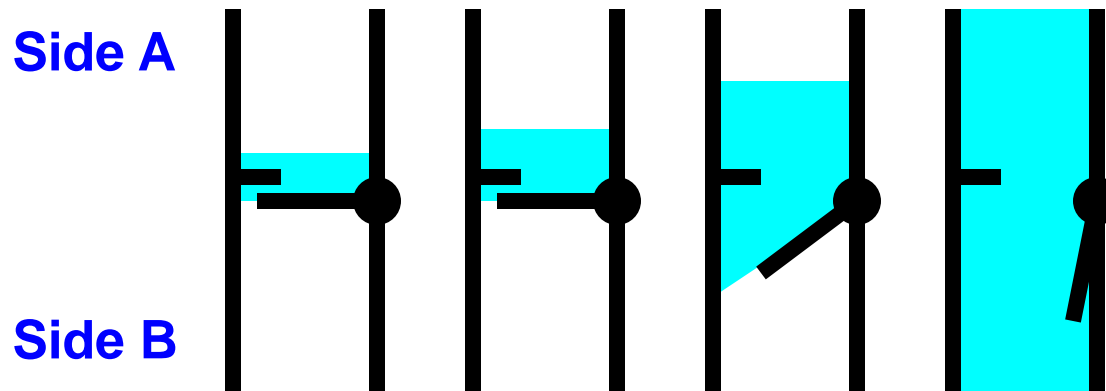

- This is not **IDEAL**.
- It finally opens with a significantly positive pressure.
- This transition is not instantaneous.

The Junction Diode

- A real valve will fail if there is too much pressure in the reverse direction.

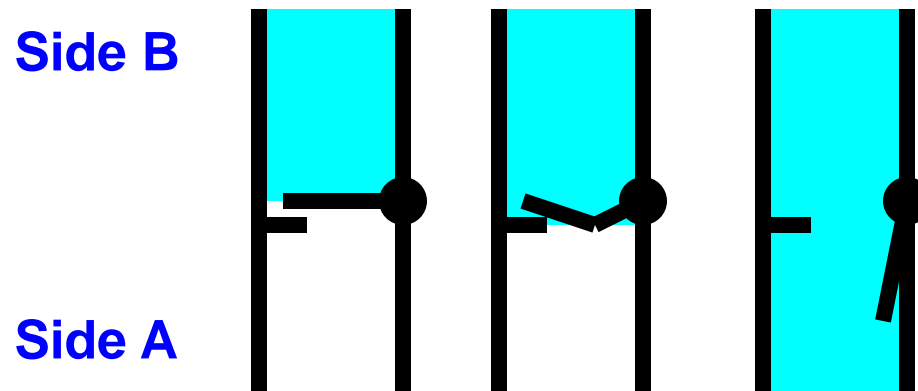

- This is not **IDEAL**.
- This transition is “almost” instantaneous ... at least compared to the previous slide.
- Is this behavior useful???

The Junction Diode

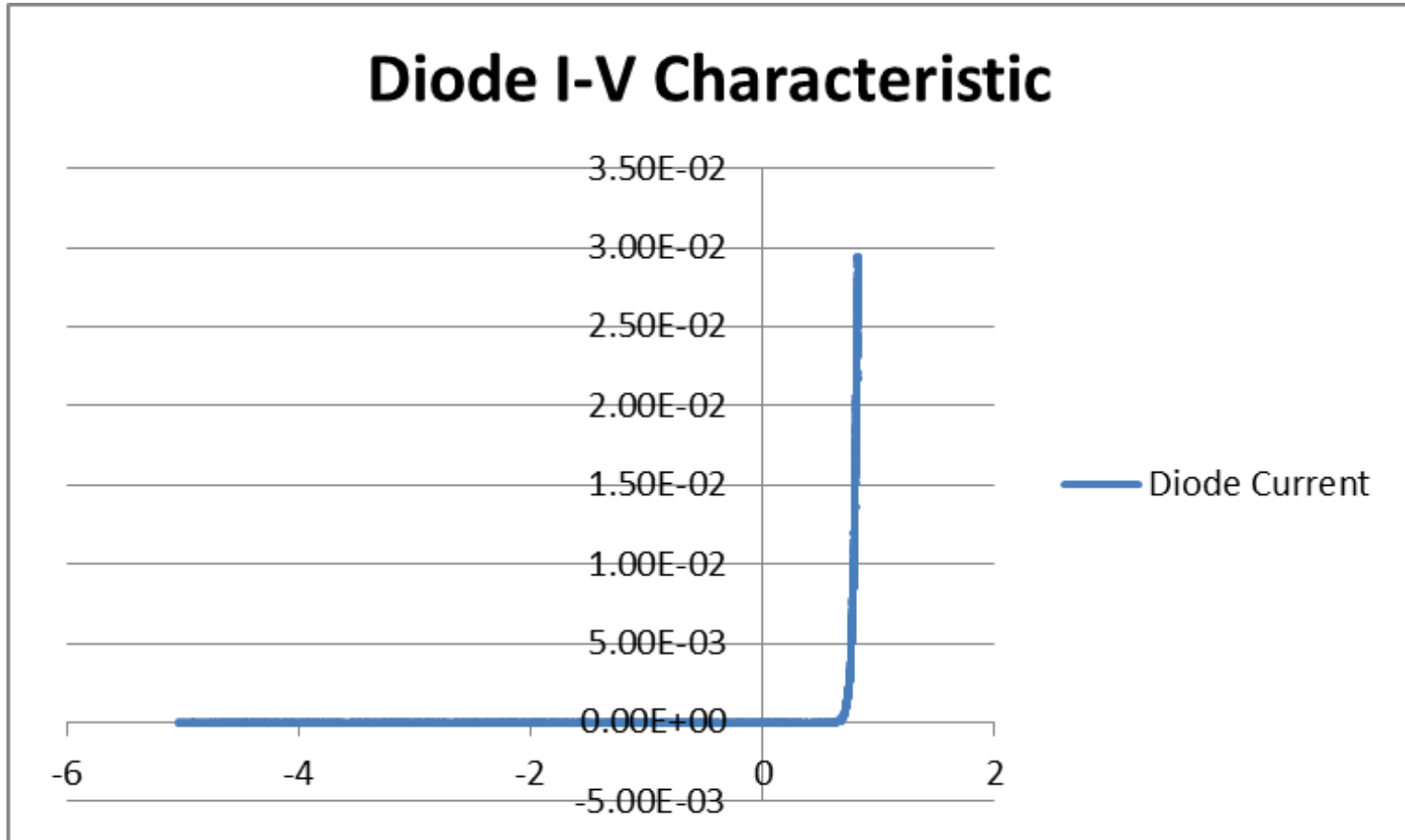

The Junction Diode

B) The Junction Diode i - v Relationship

- First let's review the Ideal Diode curve.

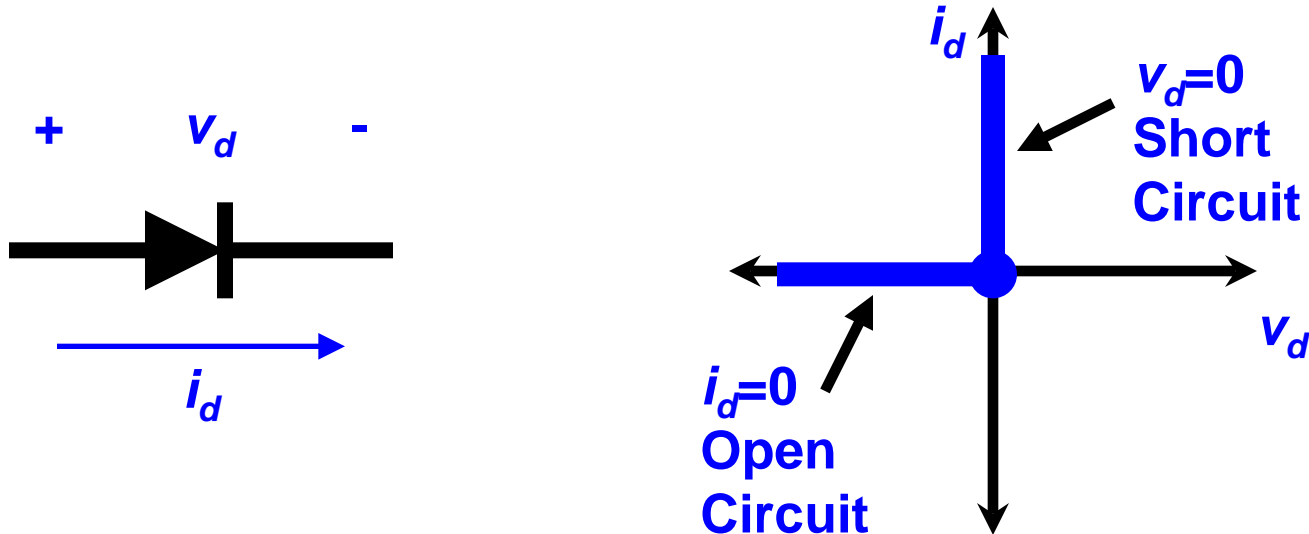

- What did we learn from the previous i - v plot and real valve?
 - a) The diode does not start conducting at $v=0$.
 - b) The diode will eventually break down in the reverse bias region.
 - c) The transitions are not instantaneous.

The Junction Diode

B) The Junction Diode i - v Relationship

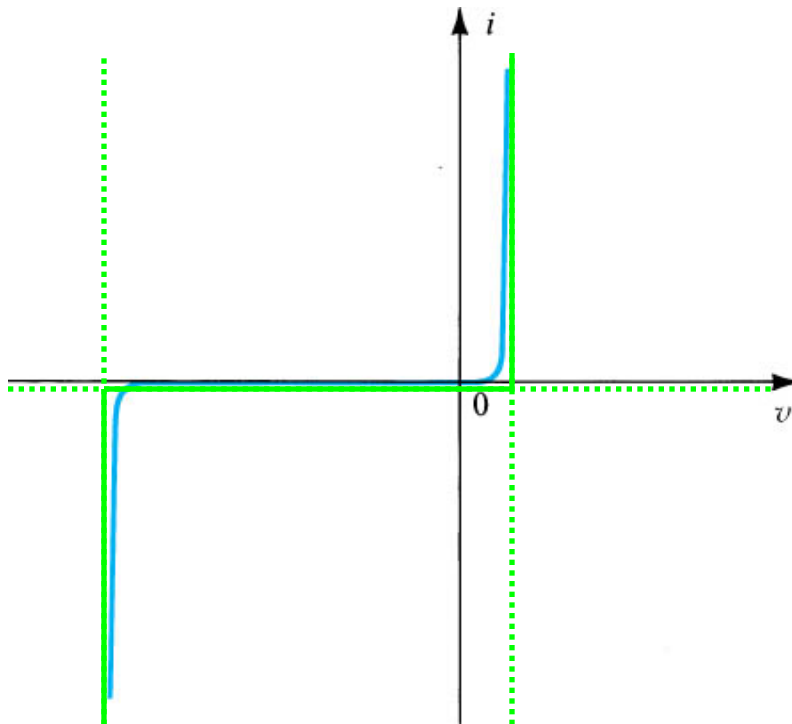
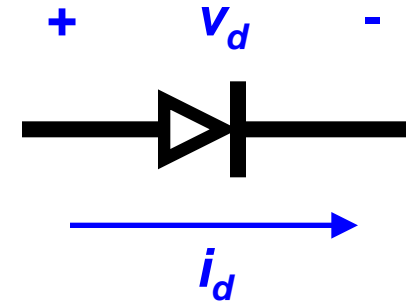

- There are 3 distinct regions of operation. (Ideal diode only had 2)
- Transitions are smooth. (Ideal diode changes are instantaneous)
- Boundaries are ambiguous. (The curve has “knees”)

We know that the curve $v=0$ is a short, but, what does $v=C$ represent?

The Junction Diode

B) The Junction Diode i - v Relationship

- In comparison to the real diode, the junction diode has three regions of operation:

1) Forward Bias: $v_d > 0$

This is related to the ideal diode acting as a short.

2) Reverse Bias: $-V_{ZK} < v_d < 0$

This is related to the ideal diode acting as an open.

3) Breakdown: $v_d < -V_{ZK}$

This is a new mode not apparent in the ideal diode.

Breakdown occurs when $v_D < -V_{ZK}$. This is a predictable behavior of junction diodes. The value V_{ZK} is known as the **zener breakdown voltage**, and is a fundamental performance parameter of any **junction diode**.

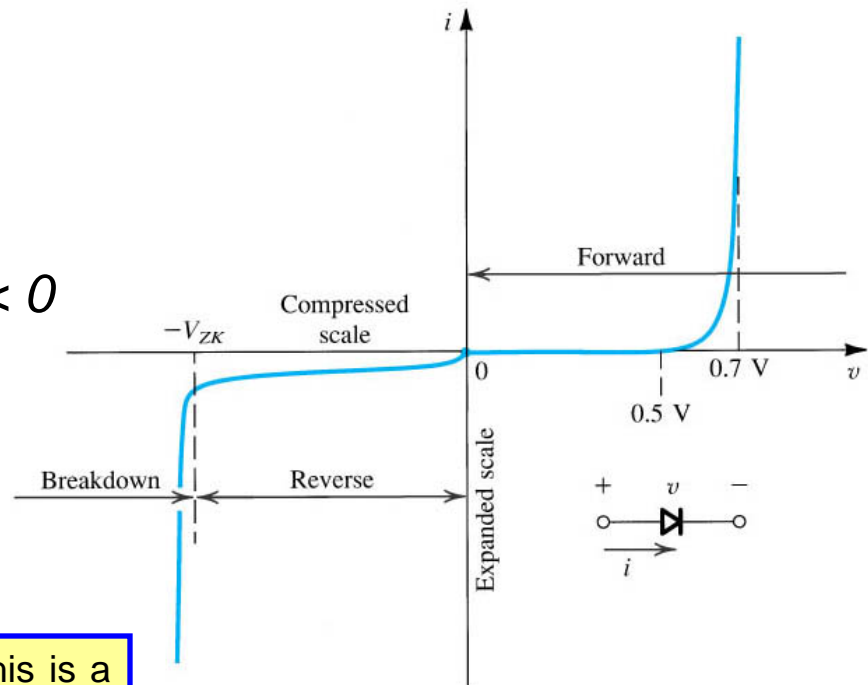

The Junction Diode (FB and RB)

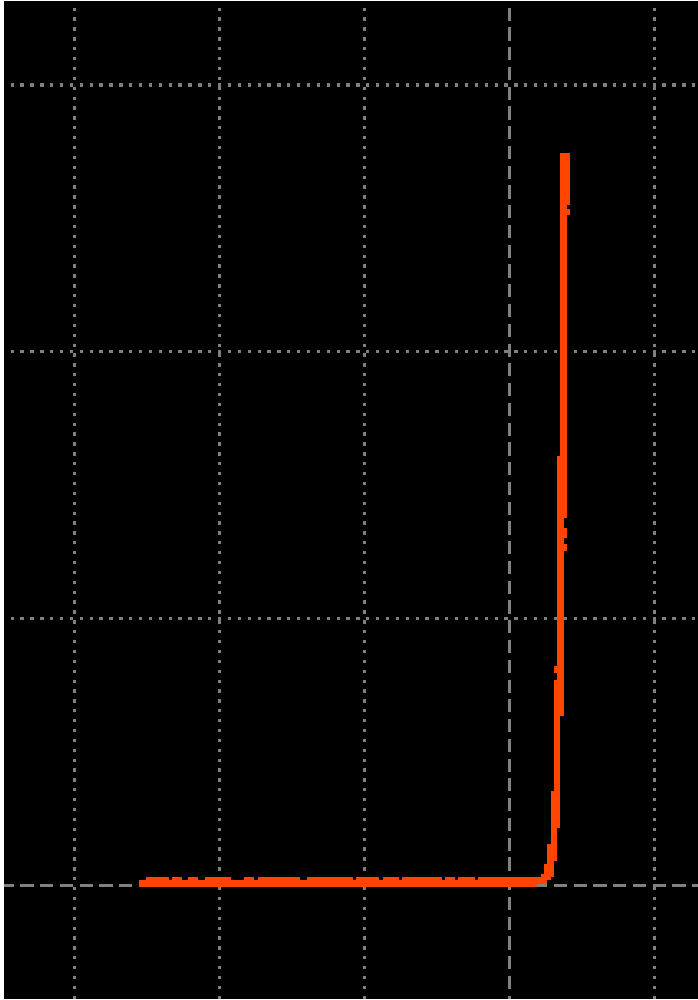

The Junction Diode (FB and RB)

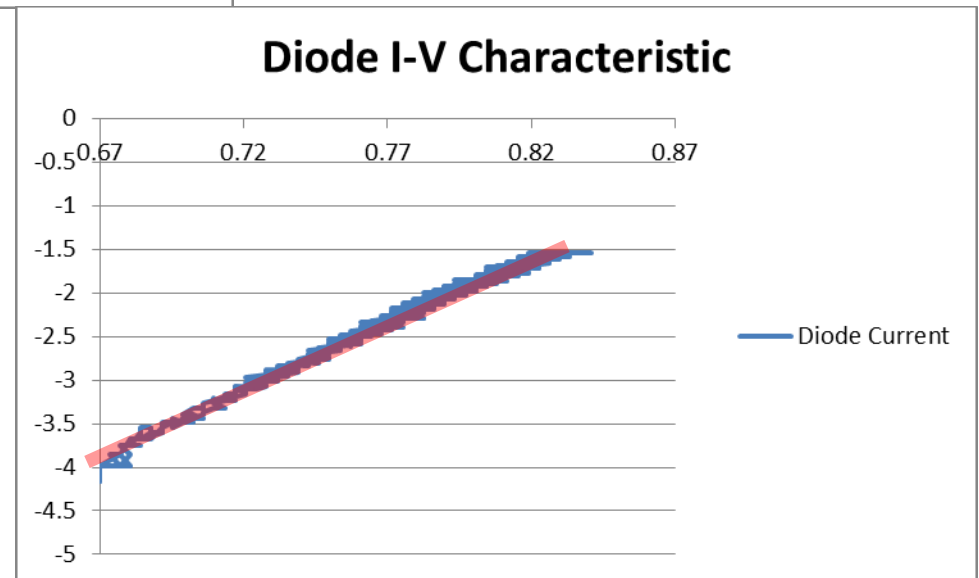
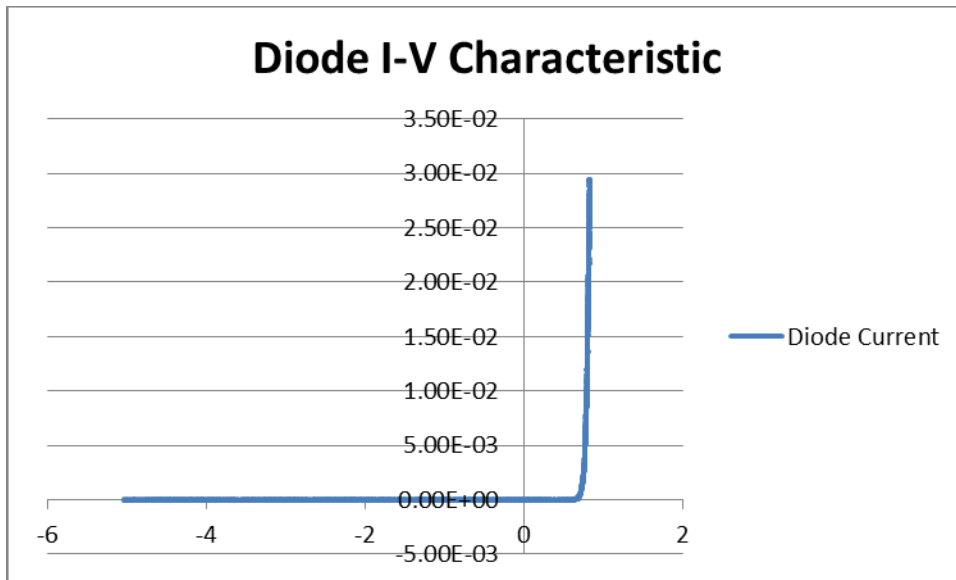

The Junction Diode

B) The Junction Diode i - v Relationship

- The Junction diode i - v relationship in the forward and reverse bias regions (**not in breakdown**) can be modeled using semiconductor physics! Therefore, we can express this relationship as a **single** function for both these regions.

$$i_D = I_S \left(e^{v_D/nV_T} - 1 \right) \quad \text{for} \quad v_D > -V_{ZK}$$

I_S : Scale Current (or Saturation Current):

- Depends on diode physical properties – material, size, and temperature.
- Proportional to junction area (remember a resistor).
- Units – Amps.
- Typical values range from 10^{-8} to 10^{-15} Amps (tiny).

The Junction Diode

B) The Junction Diode i - v Relationship

$$i_D = I_S \left(e^{v_D/nV_T} - 1 \right) \quad \text{for} \quad v_D > -V_{ZK}$$

V_T : Thermal Voltage, $V_T = kT/q$:

k : Boltzman's Constant: $1.38e-23$

T : Temperature in kelvins: $273 + ^\circ\text{C}$

q : electron charge: $1.6e-19$ coulomb

- At room temperature $\sim 20^\circ\text{C}$, V_T is approximately 25 mV.
- Unless stated otherwise, we assume this value ($V_T = 25\text{ mV}$).

n : Ideality Factor (emission coefficient).

- Fudge factor to make the equation match reality.
- Usually between 1 and 2.
- Great, now that we know this eq. that works for both F.B. and R.B., we don't need to guess the state of the diode???

The Junction Diode

Let's try: A Junction Diode Example

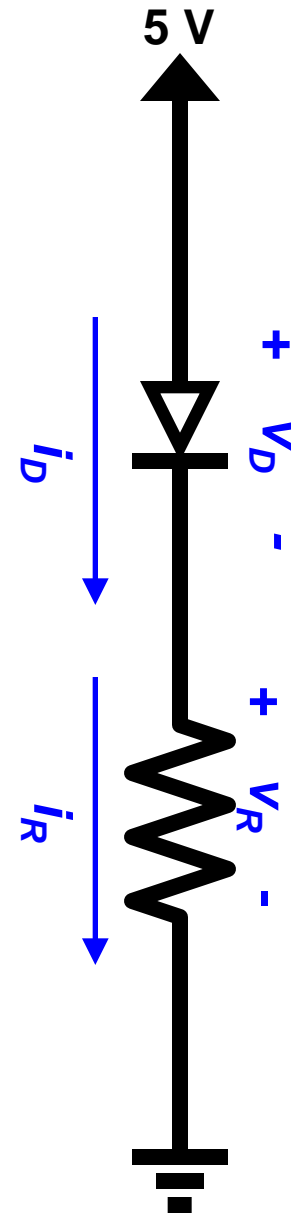

The Junction Diode

Let's try: A Junction Diode Example

$$i_D = i_R$$

$$i_R = (5 - v_D) / R$$

$$i_D = I_S (\exp(v_D / nV_T) - 1)$$

$$(5 - v_D) / R = I_S (\exp(v_D / nV_T) - 1)$$

$$5 - v_D = RI_S \exp(v_D / nV_T) - RI_S$$

$$5 - v_D + RI_S = RI_S \exp(v_D / nV_T)$$

$$(5 - v_D + RI_S) / RI_S = \exp(v_D / nV_T)$$

$$\ln(5 - v_D + RI_S) - \ln(RI_S) = (v_D / nV_T)$$

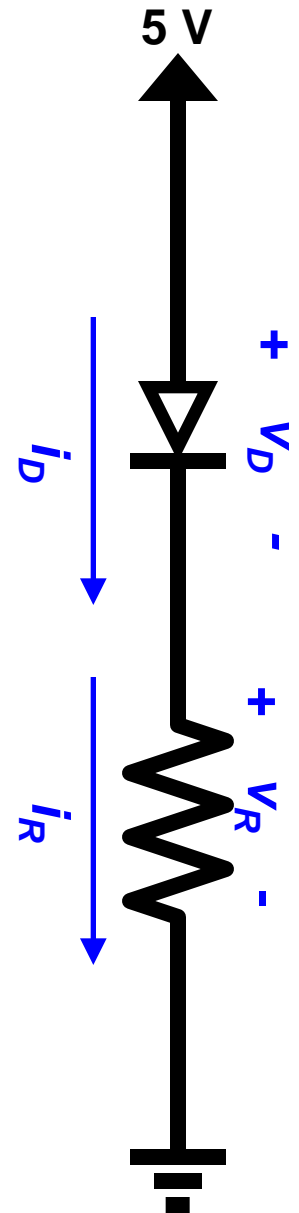

The Junction Diode

C) Forward Bias Region

$$i_D = I_S \left(e^{v_D/nV_T} - 1 \right) \quad \text{for} \quad v_D > -V_{ZK}$$

- When $v_D \gg nV_T$ this equation can be simplified.

$$v_D \gg nV_T \quad \text{then} \quad e^{v_D/nV_T} \gg 1$$

$$i_D \cong I_S e^{v_D/nV_T} \quad \text{for} \quad v_D \gg nV_T$$

- In the forward bias region there is an exponential relationship between v_D and i_D .
- Solving for v_D gives.

$$v_D = nV_T \ln\left(\frac{i_D}{I_S}\right)$$

The Junction Diode

$$i_1 = I_S e^{v_1/nV_T} \quad \text{and} \quad i_2 = I_S e^{v_2/nV_T}$$

Then

$$\frac{i_2}{i_1} = \frac{I_S e^{v_2/nV_T}}{I_S e^{v_1/nV_T}} = e^{v_2/nV_T} e^{-v_1/nV_T} = e^{(v_2 - v_1)/nV_T}$$

Or equivalently

$$v_2 - v_1 = nV_T \ln\left(\frac{i_2}{i_1}\right)$$

$$v_2 - v_1 = 2.3nV_T \log_{10}\left(\frac{i_2}{i_1}\right)$$

$$v_2 - v_1 = 0.69nV_T \log_2\left(\frac{i_2}{i_1}\right)$$

What does this mean?

- Every time the current increases by a factor of 10, the voltage increases by $2.3nV_T$. (60mV for $n=1$, and 120mV for $n=2$).
- Every time the voltage increases by $\sim 60\text{mV}$, the current is multiplied by 10.
- Every time the voltage increases by $\sim 17\text{mV}$, the current doubles.

The Junction Diode

C) Forward Bias Region

$$i_D = I_S e^{v_D/nV_T} \quad \text{for} \quad v_D \gg nV_T$$

$I_S=10^{-12}$, $V_T=25\text{mV}$, $n=1$			
v_d	I_d	R_{EFF}	Power
0.4 V	8.89 μA	45 k Ω	3.55 μW
0.5 V	485 μA	1.03 k Ω	242 mW
0.6 V	26.5 mA	22.7 Ω	15.9 mW
0.7 V	1.45 A	484 m Ω	1.01 W
0.8 V	79 A	10.1 m Ω	63.2 W
0.9 V	4.31 kA	209 $\mu\Omega$	3.88 kW

Cut-in voltage \rightarrow

$\left. \begin{array}{l} \text{0.4 V} \\ \text{0.5 V} \\ \text{0.6 V} \end{array} \right\}$ Too much resistance.
 Not really Forward Biased.

\rightarrow **0.7 V** Typical F.B. operating point.

$\left. \begin{array}{l} \text{0.8 V} \\ \text{0.9 V} \end{array} \right\}$ Way too much current.
 Diode would be destroyed.

The Junction Diode

C) Forward Bias Region

$$i_D = I_S e^{v_D/nV_T} \quad \text{for} \quad v_D \gg nV_T$$

Q. How are diodes specified (given a diode how do we find I_S , n , and V_T)?

- V_T is a function of temperature (~25mV at 20°C).

- 1) Manufacturer specifications for n and I_S .
- 2) Given a value of n , a statement such as 1mA at 0.7V can be used to determine I_S . (If just the current is given, can assume 0.7V as a standard reference for that current).
- 3) If no values are given, a simple experiment can be used.

The Junction Diode

C) Forward Bias Region

A silicon diode is a 1mA device. Find the values for the scaling constant, I_S , if $n=1$ and $n=2$.

Exercises:

$n=1.5$. Find the change in voltage from 0.1mA to 10mA.

$n=1$ is a 1mA device. Find v_d at 0.1 mA and 10mA.

The Junction Diode

C) Forward Bias Region

A silicon diode is a 1mA device. Find the values for the scaling constant, I_S , if $n=1$ and $n=2$.

$$0.001 = I_S \cdot \exp(0.7 / (0.025)), \quad I_S = 6.91 \times 10^{-16} \text{A}$$

$$0.001 = I_S \cdot \exp(0.7 / (0.050)), \quad I_S = 8.32 \times 10^{-10} \text{A}$$

Exercises:

$n=1.5$. Find the change in voltage from 0.1mA to 10mA.

$$\Delta V = nV_T \ln(i_2 / i_1) = 0.0375 * \ln(100) = 0.172 \text{V}$$

$n=1$ is a 1mA device. Find v_d at 0.1 mA and 10mA.

$$\Delta V = nV_T \ln(i_2 / i_1) = 0.0375 * \ln(10) = 0.058 \text{V}$$

$$V(0.0001) = 0.7 - 0.058 = 0.642 \text{V}$$

$$V(0.0100) = 0.7 + 0.058 = 0.758 \text{V}$$

The Junction Diode

C) Forward Bias Region

Temperature variations.

- V_T varies directly with temperature (previous slide).
- I_S also varies with temperature by increasing by 15% for every 1°C rise in temperature.

$$I_{S2} = I_{S1} * 1.15^{(T2-T1)}$$

- For every ~5°C rise in temperature I_S will double.

The Junction Diode

A Junction Diode Example: Forward Bias

- Solve using a computer (ADS) for values of R and V .

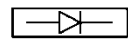

Diode_Model
DIODEM1
 Is= Bv= Vjsw=
 Rs= Ibv= Fcsw=
 Gleak= Nbv= AllowScaling=no
 N= IbvI= Tnom=
 Tt= NbvI= Trise=
 Cd= Kf= Xti=
 Cjo= Af= Eg=
 Vj= Ffe= AllParams=
 M= Jsw=
 Fc= Rsw=
 Imax= Gleaksw=
 Imelt= Ns=
 Isr= Ikp=
 Nr= Cjsw=
 Ikf= Msw=

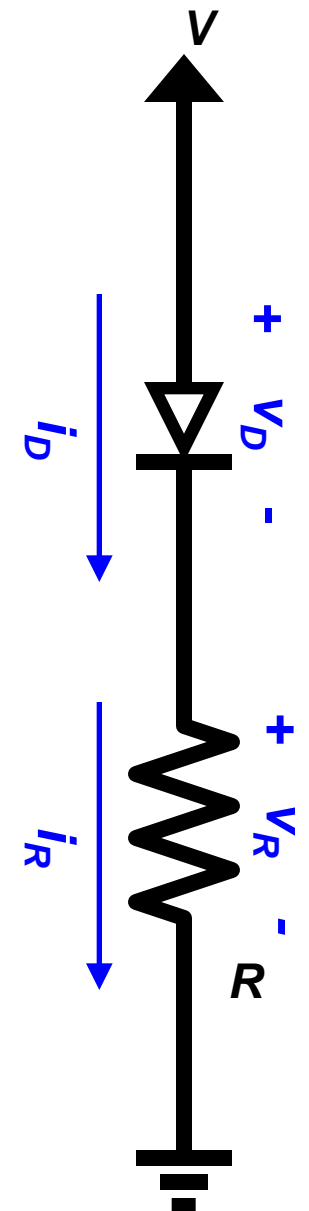
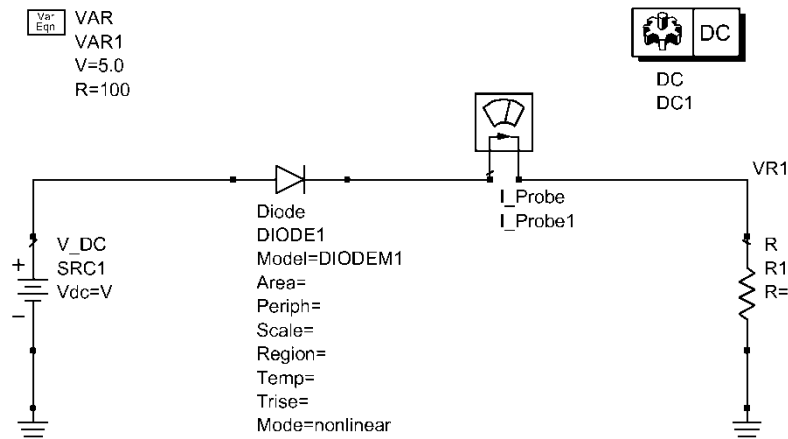

The Junction Diode

A Junction Diode Example: Forward Bias

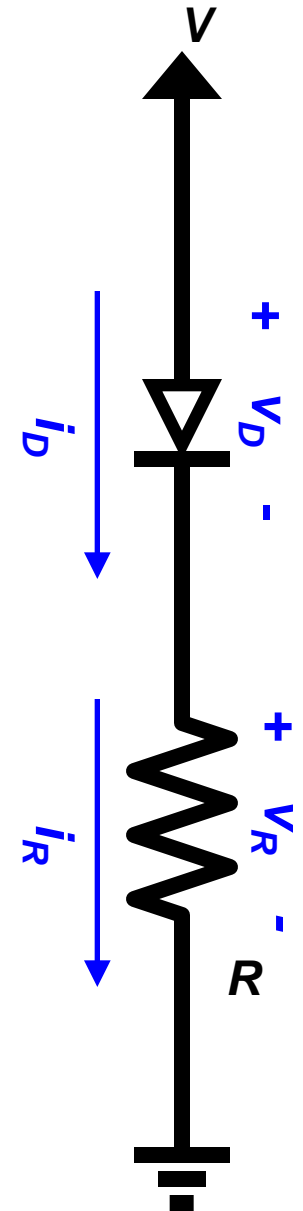
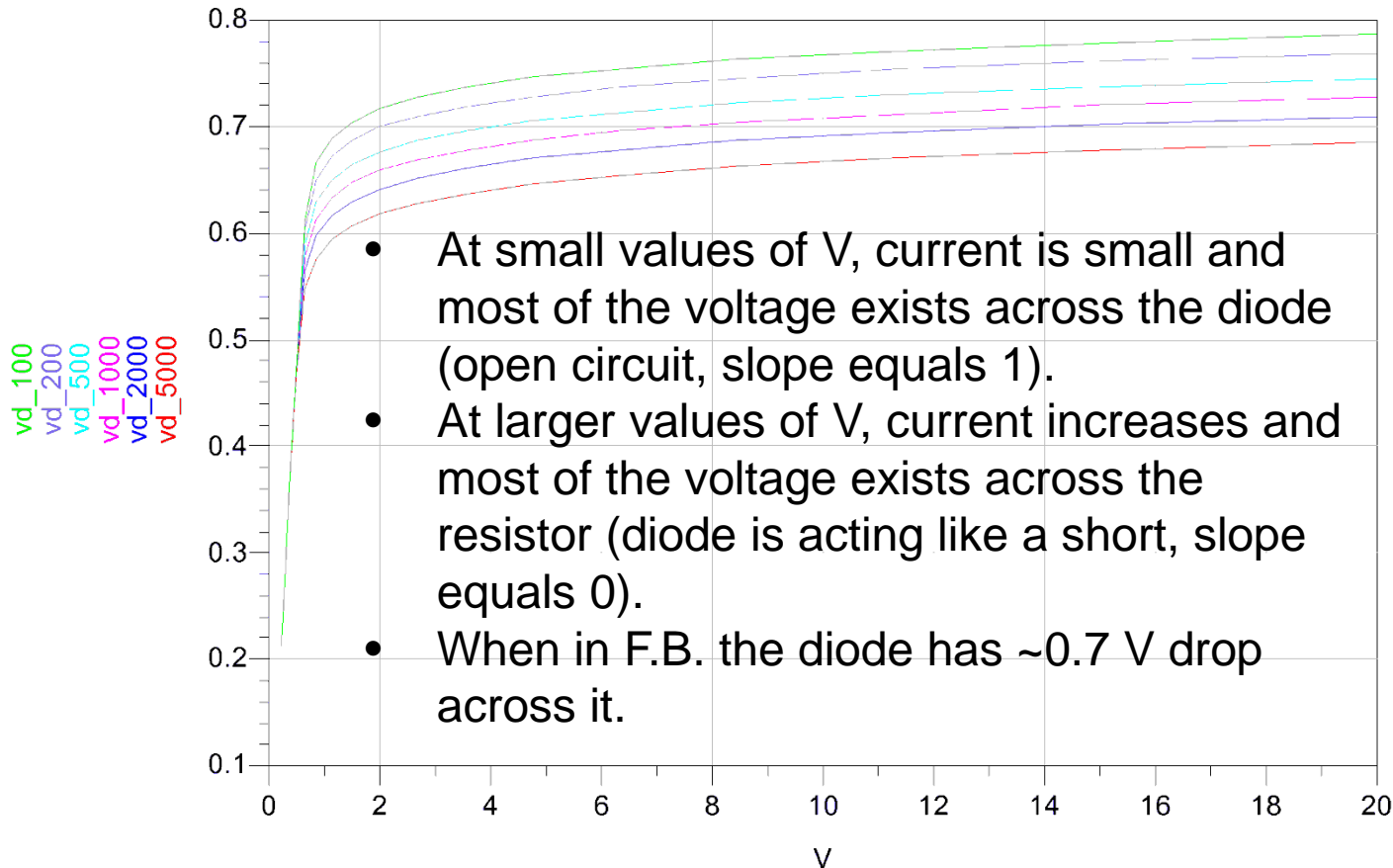

The Junction Diode

A Junction Diode Example: Forward Bias

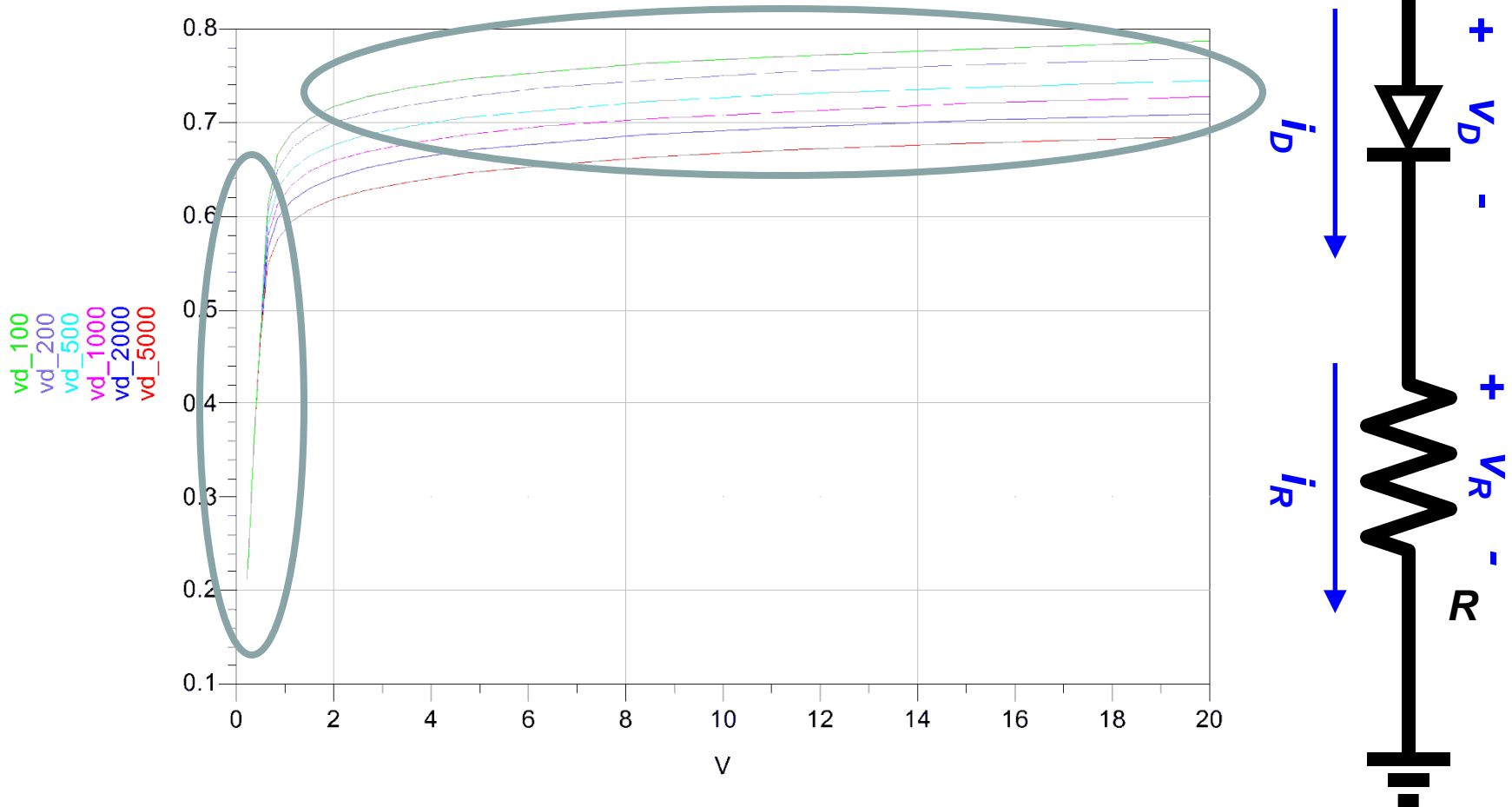

The Junction Diode

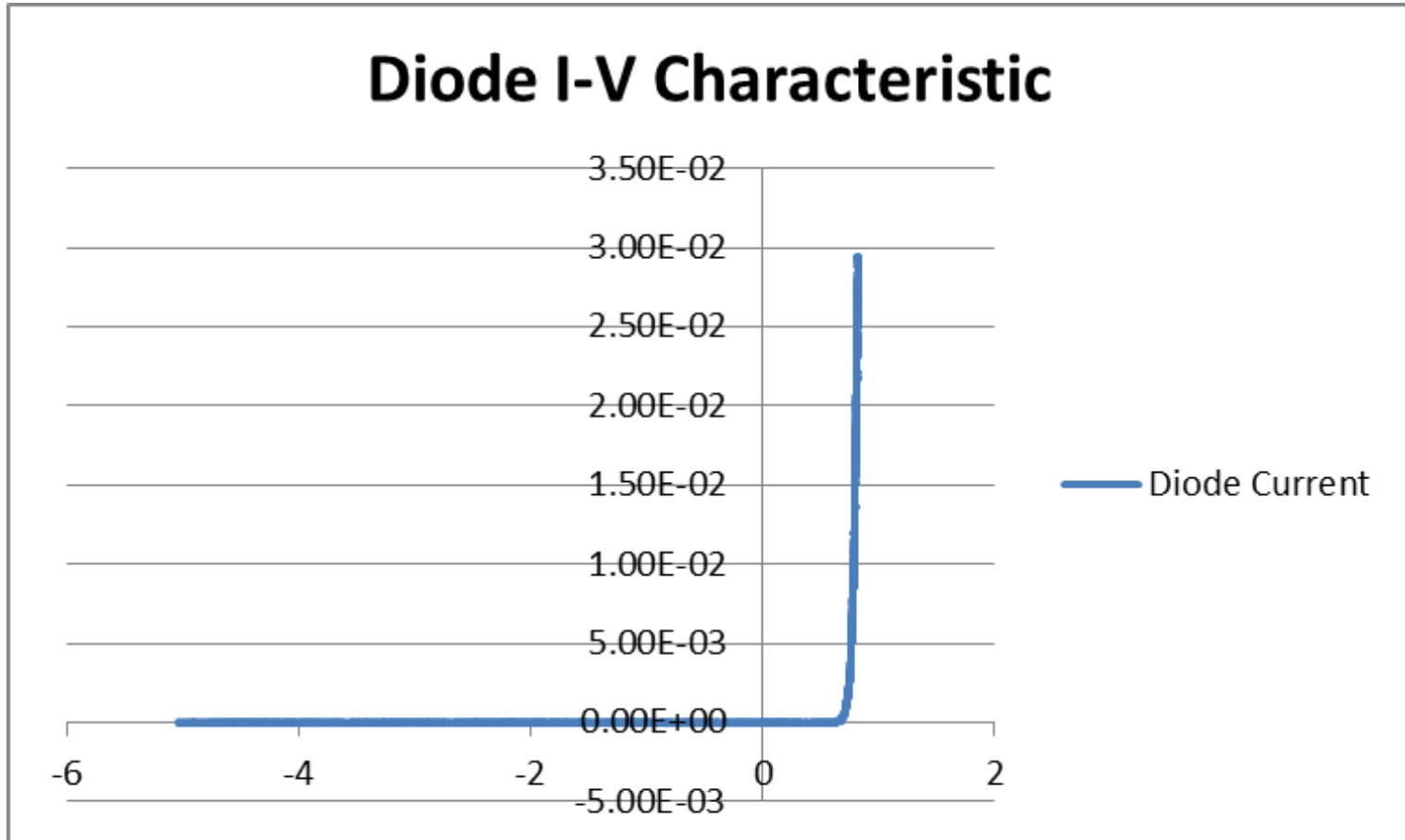

The Junction Diode

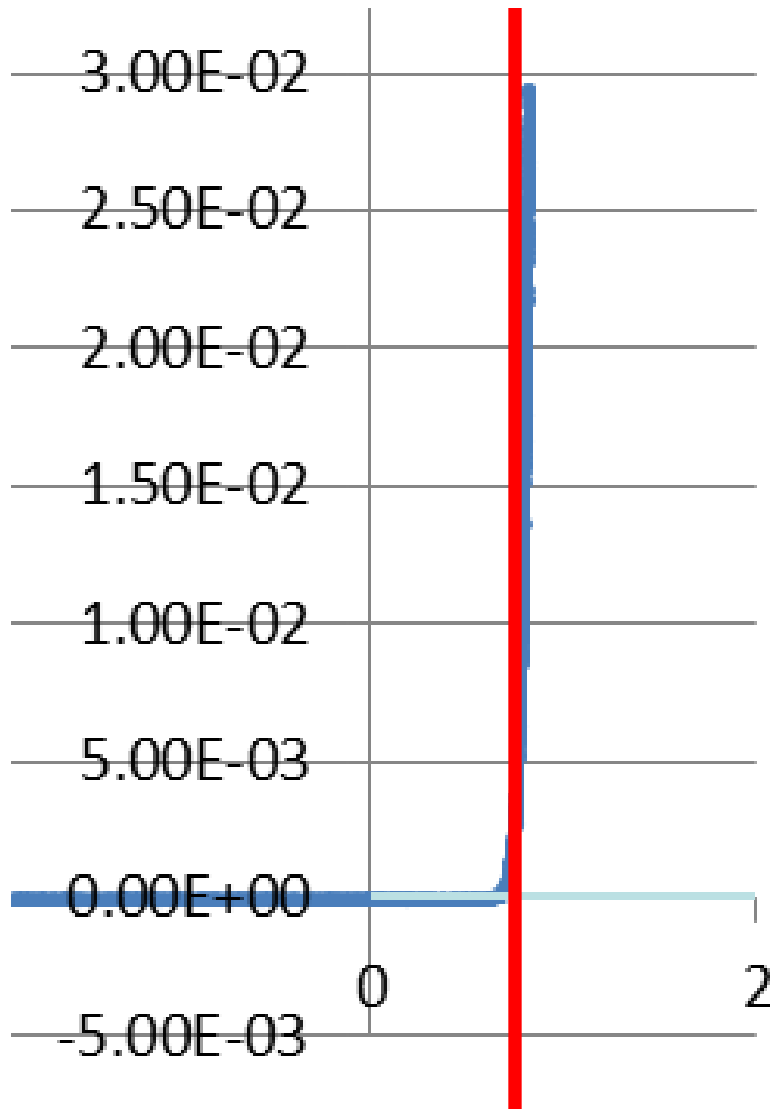

- From approximately 1mA to 30mA, the voltage across the diode is very close to 0.7V.
- A vertical line is a voltage source.
- For this diode in FB, a very good guess (or model) for the diode would be a 0.7V voltage source.

The Junction Diode

C) Reverse Bias Region

$$i_D = I_S \left(e^{v_D/nV_T} - 1 \right) \quad \text{for} \quad v_D > -V_{ZK}$$

- When $v_d \ll -nV_T$ this equation can be simplified.

$$v_D \ll -nV_T \quad \text{then} \quad e^{v_D/nV_T} \cong 0$$

$$i_D \cong -I_S \quad \text{for} \quad v_D \ll -nV_T$$

- In the reverse bias region there is a constant value for i_d .
- Thus the name saturation current.
- Real diodes also exhibit a leakage currents that are typically much larger than I_S . These currents tend to dominate
- Temperature Dependence: Whereas I_S double for every 5°C , the R.B. current doubles for every 10°C .

The Junction Diode

C) Breakdown Region

- Occurs when the magnitude of the reverse voltage exceeds a certain threshold value specific to the particular diode.
- This value is denoted as V_{ZK} : Zener-Knee Voltage.
Typically around 25V.
- Fall-off in this region is steep.
- Mechanism for breakdown is non-destructive; however, diode breakdown can result in a significant amount of power dissipated within the diode, and this can be destructive.

$P_{R.B.} = I_S * V_D$	very small
$P_{F.B.} = 0.7 * i_D$	moderate
$P_{B.D.} = V_{ZK} * i_D$	potentially destructive